

# CARBURETOR

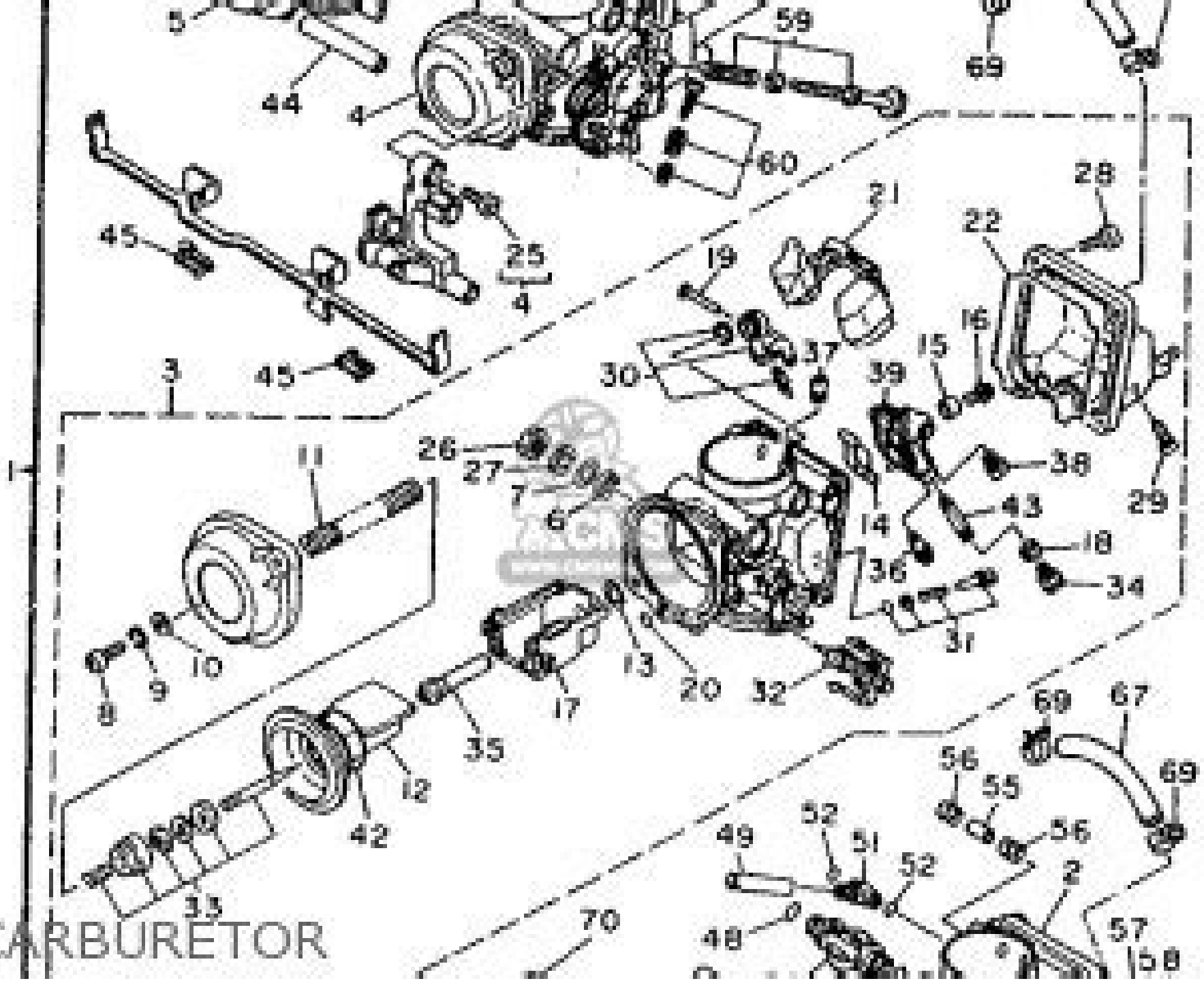

# Xj600 Engine Diagram

**Penton Staff**



# Xj600 Engine Diagram

WALNECK'S CLASSIC CYCLE TRADER, FEBRUARY 2004 Causey Enterprises, LLC, Motorcycle Workshop Practice  
Techbook John Haynes,2016-10-03 Haynes has discovered all the problems that motorcycle owners could possibly encounter when rebuilding or repairing their bikes Documenting the most common DIY fixes with hundreds of illustrations and step by step instructions this compendium of repair modification and troubleshooting advice is applicable to all domestic and import marques Acceleration and Passing Ability United States. National Highway Traffic Safety Administration,1973 Clymer  
Yamaha XV535-1100 Virago 1981-2003: Service, Repair, Maintenance Ed Scott,2004-05-30 Service repair and maintenance manual **Honda CB750** Mark Haycock,2000 The Honda CB750 was the first modern large motorcycle to combine speed luxury and reliability in an affordable package Mr Honda himself described it as the King of Motorcycles This fascinating work contains the complete background history of Honda design and development history in depth technical analysis and full specifications Superbly illustrated Hardcover 7 1 2 x 9 1 2 176 pages 32 color 150 b w The Glass Cell Patricia Highsmith,2004-06-17 At last back in print one of Patricia Highsmith s most disturbing works Rife with overtones of Dostoyevsky The Glass Cell first published forty years ago combines a quintessential Highsmith mystery with a penetrating critique of the psychological devastation wrought by the prison system Falsely convicted of fraud the easygoing but naive Philip Carter is sentenced to six lonely drug ravaged years in prison Upon his release Carter is a more suspicious and violent man For those around him earning back his trust can mean the difference between life and death The Glass Cell s bleak and compelling portrait of daily prison life and the consequences for those who live it is sadly as relevant today as it was when the book was first published in 1964 Clymer Honda 600 Hurricane 1987-1990 Penton Staff,1992-08-01 The Honda 600 Hurricane is a very popular machine built with precision engineering to ensure a long life on the road With the help of the Clymer Honda 600 Hurricane 1987 1990 Repair Manual in your toolbox you will be able to maintain service and repair your motorcycle to extend its life for years to come Clymer manuals are very well known for their thorough and comprehensive nature This manual is loaded with step by step procedures along with detailed photography exploded views charts and diagrams to enhance the steps associated with a service or repair task This Clymer manual is organized by subsystem with procedures grouped together for specific topics such as front suspension brake system engine and transmission It includes color wiring diagrams The language used in this Clymer repair manual is targeted toward the novice mechanic but is also very valuable for the experienced mechanic The service manual by Clymer is an authoritative piece of DIY literature and should provide you the confidence you need to get the job done and save money too Manufacturers' Standard Specifications ... Association of American Steel Manufacturers,1923 **Yamaha XJ600 SECA II 92-98** Penton Staff,2000-05-24 XJ600S Seca II 1992 1998 U S XJ600S Seca II 1992 1996 Canada XJ600S Diversion 1992 1998 U K XJ600SC

Seca II 1992 1998 California XJ600S Seca II 1992 1996 Australia [Clymer Yamaha XJ550, XJ600 & FJ600 1981-1992](#)  
Penton Staff,1996-03-01 With the help of the Clymer Yamaha XJ550 XJ600 FJ600 1981 1992 Repair Manual in your toolbox you will be able to maintain service and repair your motorcycle to extend its life for years to come Clymer manuals are very well known for their thorough and comprehensive nature This manual is loaded with step by step procedures along with detailed photography exploded views charts and diagrams to enhance the steps associated with a service or repair task This Clymer manual is organized by subsystem with procedures grouped together for specific topics such as front suspension brake system engine and transmission It includes color wiring diagrams The language used in this Clymer repair manual is targeted toward the novice mechanic but is also very valuable for the experienced mechanic The service manual by Clymer is an authoritative piece of DIY literature and should provide you the confidence you need to get the job done and save money too **Norton** Mick Woollett,2004 The Untouchable Norton is how racer Rem Fowler described his machine after winning the twin cylinder class of the first TT in 1907 The company would use the phrase in advertising for the next 50 years This book charts the history of one of the oldest marques in the world both the glorious racing tradition and the production machines from the first clip on engines to the F1 rotary superbike Interviews with those closely involved including James Norton s daughter Grace who kindly provided original documents and photographs reproduced here for the first time make this the definitive account of a key contribution to motorcycle history [Yamaha XJ600S & XJ600N](#) Alan Ahlstrand,John Harold Haynes,1999

### **les 10 livres à lire sur les allergies** - Jan 11 2022

le grand livre des allergies par collectif aux éditions eyrolles les maladies allergiques ont fortement augmenté au cours des dernières décennies pour quelles raisons sous quelle

### **le grand livre des allergies de ffa livre decitre** - Apr 25 2023

apr 25 2014 cet ouvrage pratique concret largement illustré et enrichi de réponses de spécialistes à des questions de patients donne toutes les clés pour comprendre les

### **le grand livre des allergies fédération française d allergologie** - Apr 13 2022

medical books cme courses world of medical ebooks pdf epub and cme video courses

### **le grand livre des allergies collectif ebook vie de famille** - Nov 08 2021

### **amazon fr commentaires en ligne le grand livre des allergies** - Jun 15 2022

téléchargement gratuit de livres le grand livre des allergies fédération française d allergologie ffa disponible en pdf epub et kindle lisez écrivez des critiques et bien

**le grand livre des allergies de ffa multi format decitre** - Sep 18 2022

seul ouvrage à proposer une approche pluridisciplinaire nécessaire à la prise en charge des différentes maladies allergiques  
le grand livre des allergies offre de nombreux schémas et

le grand livre des allergies le grand livre de format kindle - May 27 2023

achetez et téléchargez ebook le grand livre des allergies le grand livre de boutique kindle maladies et dépendances amazon fr

*le grand livre des allergies pdf epub ebook* - Dec 22 2022

les maladies allergiques ont fortement augmenté au cours des dernières décennies pour quelles raisons accueil recherche livres romans fictions loisirs pratique

*le grand livre des allergies ebook de fédération française d* - Jan 23 2023

le grand livre des allergies fédération française d allergologie ffa br les maladies allergiques ont fortement augmenté au cours des dernières décennies pour quelles

le grand livre des allergies amazon fr - Sep 30 2023

cet ouvrage pratique concret largement illustré et enrichi de réponses de spécialistes à des questions de patients donne toutes les clés pour comprendre les mécanismes de l allergie

**le grand livre des allergies collectif eyrolles** - Nov 20 2022

aug 29 2014 retrouvez l ebook le grand livre des allergies de ffa Éditeur eyrolles format e book multi format librairie decitre votre prochain livre est là

**le grand livre des allergies fédération française d allergologie** - Jun 27 2023

un voyage vers soi grâce au souffle le guide indispensable pour comprendre toutes les allergies les maladies allergiques ont fortement augmenté au cours des dernières décennies

*le grand livre des allergies ffa livres furet du nord* - May 15 2022

lee ahora en digital con la aplicación gratuita kindle le grand livre des allergies le grand livre de french edition ebook fédération française d allergologie ffa amazon es

le grand livre des allergies medical books cme courses - Feb 09 2022

jun 8 2023 le grand livre des allergies le grand livre de by fédération française d allergologie ffa le grand livre des allergies le grand livre de by fédération française

**le grand livre des allergies google books** - Jul 29 2023

seul ouvrage à proposer une approche pluridisciplinaire nécessaire à la prise en charge des différentes maladies allergiques  
le grand livre des allergies offre de nombreux

*le grand livre des allergies nextory com - Oct 20 2022*

retrouvez les sélections de livres nos coups de cœurs nos animations nos dédicaces ainsi que tous nos évènements accueil le grand livre des allergies catalogue

**le grand livre des allergies ed 1 bibliovox la bibliothèque - Jul 17 2022**

apr 25 2014 le grand livre des allergies de plongez vous dans le livre ffa au format ajoutez le à votre liste de souhaits ou abonnez vous à l auteur ffa livraison gratuite à

**le grand livre des allergies fédération française - Feb 21 2023**

lisez le grand livre des allergies de fédération française d allergologie ffa disponible chez rakuten kobo les maladies allergiques ont fortement augmenté au cours des dernières

*le grand livre des allergies le grand livre de french edition - Mar 13 2022*

sep 19 2015 le grand livre des allergies la fédération française d allergologie est une association dont le but est de valoriser la place des allergies dans le système de santé

**le grand livre des allergies le libr air - Aug 18 2022**

découvrez des commentaires utiles de client et des classements de commentaires pour le grand livre des allergies sur amazon fr lisez des commentaires honnêtes et non biaisés

le grand livre des allergies fnac - Aug 30 2023

apr 25 2014 le grand livre des allergies tout savoir sur la prévention et les traitements tous les allergènes de a à z broché benoît wallaert joëlle birnbaum ffa societe

le grand livre des allergies collectif 2212557620 cultura - Mar 25 2023

le grand livre des allergies par collectif aux éditions eyrolles les maladies allergiques ont fortement augmenté au cours des dernières décennies pour quelles raisons sous quelle

le grand livre des allergies le grand livre de by fédération - Dec 10 2021

**department of citywide required information - Aug 21 2022**

web 2 2 nys probation officer exam study guide 2020 08 09 administrators and the nys division of parole this particular safety training was awarded the systems approach

exam study guides resources nycourts gov new york - Oct 23 2022

web oct 24 2016 probation officer exam secrets study guide nyc civil service exam practice questions test review for the new york city probation officer exam nyc

*new york state department of civil service sullivan us - Sep 02 2023*

web the new york state department of civil service has developed this test guide to familiarize you with the written test for entry level local probation and entry level state

*nysprobationofficerexamstudyguide pdf git livnsense* - Mar 16 2022

web documents of the senate of the state of new york nys probation officer exam study guide downloaded from helpdesk bricksave com by guest madalynn hodges

**nys probation officer exam study guide helpdesk bricksave** - Dec 13 2021

**how to prepare for probation officer exam 2023 study guide** - Jun 18 2022

web civil service exam study guide test prep secrets for police officer firefighter postal and more over 400 practice questions step by step review probation employment

**free probation officer exam preparation test prep xp** - Jun 30 2023

web introduction the new york state department of civil service has developed this test guide to familiarize you with the written test used for the probation examination series the

**exam study guides resources nycourts gov exam** - Jan 26 2023

web court security series exams exam study guides subject matter sample related nys court officer trainee jg 16 exam clear to public minimum

probation officer exam preparation 2023 practice4me - Mar 28 2023

web faqs general exam info exam study guides results note exam news filing frank 10 a m september 20 2023 to october 19 2023 associate court

probation officer exam secrets study guide nyc civil service - Jul 20 2022

web feb 23 2021 minimum qualification and new york city employment requirements you must be currently employed by new york city as a provisional probation officer

**nys probation officer exam study guide** - May 18 2022

web they make preliminary investigations of defendants alleged crimes or offenses obtain information on offenders legal economic and psycho social history and background

*mayor bureau of examinations notice of* - Feb 12 2022

web the system will automatically log you out after 15 minutes of inactivity therefore please save your data if you step away the system will be unavailable every day between 2 am

*exams careers nycourts gov a guide to the written* - Feb 24 2023

web court security production exams take study guides subject matter sample questions nys court officer trainee jg 16 exam

open to public minimum

**a guide to the written test monroe county ny** - May 30 2023

web exam preparation guides sample exams are available for the following title series court security court clerk court interpreter court reporter office clerical court

oasys oasys new york city - Nov 11 2021

**how to prepare for probation officer exam 2023 study guide** - Aug 01 2023

web this is a free guide for the probation officer exam learn about the different aspects of the test and use practice tests and exercises in order to come as prepared as you can

*notice of examination nyc gov* - Apr 16 2022

web oct 22 2023 nys probation officer exam study guide 2011 09 01 1 24 nys probation officer exam study guide

introduction nys probation officer exam study guide

exam study guides resources nycourts gov judiciary - Apr 28 2023

web what is the probation officer exam the probation officer exam is a pre employment screening measure that assesses a prospective candidate s aptitude for a variety of

**probation officer civil service test study guide books** - Sep 21 2022

web obtain all the information you need around becoming pass the probation office exam in our fresh study guide sample questions

nys probation officer exam study guide pdf - Jan 14 2022

exams careers nycourts gov judiciary of - Dec 25 2022

web product description comprehensive test preparation materials for the probation officer exam this probation officer test study guide book includes everything you need to

**free online probation officer practice quiz** - Nov 23 2022

web they make preliminary investigations of defendants alleged crimes or offenses obtain information on offenders legal economic and psycho social history and background

new york state office of probation and correctional alternatives - Oct 03 2023

web probation officer positions are open competitive civil service positions in new york state each candidate must meet the minimum requirements of a graduate degree in many of

□□ □ □ □ □□ □ □□ □ □ □ □□ □ □□ □ **basic tally prime dtp** - Feb 25 2022



web if any question in your mind related computer this live video is very important for you see immediately and watching full video computercourse computercla

[tally dca sem 1 festival rai dance](#) - May 11 2023

web without difficulty as acquire handbook tally dca sem 1 it will enormously relaxation you to see tutorial tally dca sem 1 as you such as access the tally dca sem 1 join that we

**dca tally online test in english dca tally online mcq in english** - Mar 29 2022

web feb 13 2019 the dca full mock test paper is free for all students this paper has 30 questions time allowed is 30 minutes the dca online mock test exam for tally is

**tally dca sem 1 help environment harvard edu** - Sep 03 2022

web 1 tally dca sem 1 recognizing the way ways to acquire this ebook tally dca sem 1 is additionally useful you have remained in right site to begin getting this info acquire the

**tally dca sem 1 bespoke cityam** - May 31 2022

web tally dca sem 1 chandna computers 434 likes 1 talking about this dca pgdca batch start from 1st jun tally internet batch started from ist jun dca i sem result 1 dca 1

**dca tally online test in english dca tally online mcq in english** - Jan 27 2022

web jul 28 2023 the dca full mock test paper is free for all students this paper has 30 questions time allowed is 30 minutes the dca online mock test exam for tally is

[tally dca sem 1 clr imymac com](#) - Aug 02 2022

web 2 tally dca sem 1 2020 07 06 decisions involved in os design because they are embedded into the text as end of chapter material students are able to apply them right

*tally dca sem 1 orientation sutd edu sg* - Feb 08 2023

web tally dca sem 1 dca course in india dir indiamart com july 27th 2017 get contact details and address of dca course firms and companies 1st semester same as dca

**tally dca sem 1 tvl parisbytrain com** - Oct 24 2021

web tally dca sem 1 april 14th 2018 prasann infotech website we provide coaching to bca students of all semester more than 1 subjects i have studied dca tally and dtp

*tally dca sem 1 uniport edu ng* - Jul 01 2022

web jun 25 2023 tally dca sem 1 2 10 downloaded from uniport edu ng on june 25 2023 by guest changing connections and resilient enough to stand up to the huge flows of data

*tally dca sem 1 uniport edu ng* - Oct 04 2022

web may 6 2023 tally dca sem 1 1 14 downloaded from uniport edu ng on may 6 2023 by guest tally dca sem 1 recognizing the exaggeration ways to get this ebook tally dca

**tally dca sem 1 tvl parisbytrain com** - Aug 14 2023

web tally dca sem 1 april 12th 2018 diploma in computer application dca 6 months semester 1 module 1 computer concepts amp fundamentals operating system

*tally dca sem 1 online kptm edu my* - Jul 13 2023

web jul 4 2023 tally dca sem 1 free download dca pgdca notes in hindi for makhanlal iact institute for advanced computer technology computer career courses lcc

tally dca sem 1 pdf pdf linguisticschool com - Jun 12 2023

web apr 9 2023 1 tally dca sem 1 pdf right here we have countless book tally dca sem 1 pdf and collections to check out we additionally find the money for variant types and

**tally dca sem 1 orientation sutd edu** - Sep 22 2021

web started from ist jun dca i sem result 1 pgdca ii semester assignments tally topics s no topic 1 what is accounting dca 1st sem dca 2nd sem pgdca 1st sem pgdca

**tally academy tally education tally academy franchise tally** - Apr 29 2022

web overview advanced diploma in computer application dca is the most popular course especially for students studying vocational courses at itis itcs students who have

*tally dca sem 1 erp ecomobi com* - Nov 05 2022

web tally dca sem 1 tally dca sem 1 free download here pdfsdocuments2 com help center exam papers pgdca tally computer fundamentals mcq for dca 1st sem 05 dca

*tally dca sem 1 orientation sutd edu sg* - Nov 24 2021

web tally dca sem 1 tally dca sem 1 syllabus dca 180 hours 1 computer data storage 02 dca pgdca i sem fundamental of computer block diagram iact institute for

*tally dca sem 1 tvl parisbytrain com* - Mar 09 2023

web april 10th 2018 dca duration 6 months eligibility sem 1 fundamental of computer sem 2 internet html tally corel draw photoshop 05 dca pgdca i sem fox pro use of list

tally dca sem 1 discourse reconstructingjudaism org - Jan 07 2023

web tally dca sem 1 courses welcome to keerti computer institutes exam time table may 2017 cyberdairy solutions aakanksha shrivastava linkedin search pgdca april

tally dca sem 1 pdf copy voto uneal edu - Dec 06 2022

web tally dca sem 1 pdf whispering the strategies of language an emotional quest through tally dca sem 1 pdf in a digitally driven earth where displays reign supreme and

*tally dca sem 1 orientation sutd edu sg* - Dec 26 2021

web february 15th 2018 tally erp 9 pgdca dca 10am 12pm dtp 11am 01pm tally 12pm 02pm new batch open 1 semester february 2nd semester

tally dca sem 1 jetpack theaoi - Apr 10 2023

web india tally course content dca t sem 1 tally system analysis amp design pc packages mcq for dca 1st sem pc package ms office multiple choice question for dca 1st

## **Xj600 Engine Diagram** Book Review: Unveiling the Power of Words

In a global driven by information and connectivity, the energy of words has are more evident than ever. They have the ability to inspire, provoke, and ignite change. Such could be the essence of the book **Xj600 Engine Diagram**, a literary masterpiece that delves deep to the significance of words and their impact on our lives. Published by a renowned author, this captivating work takes readers on a transformative journey, unraveling the secrets and potential behind every word. In this review, we will explore the book is key themes, examine its writing style, and analyze its overall affect readers.

[https://offsite.creighton.edu/files/virtual-library/Documents/moriah\\_plath\\_anorexic.pdf](https://offsite.creighton.edu/files/virtual-library/Documents/moriah_plath_anorexic.pdf)

[https://offsite.creighton.edu/files/virtual-library/Documents/music\\_notes\\_in\\_word.pdf](https://offsite.creighton.edu/files/virtual-library/Documents/music_notes_in_word.pdf)

[https://offsite.creighton.edu/files/virtual-library/Documents/my\\_daughter\\_has\\_borderline\\_personality\\_disorder.pdf](https://offsite.creighton.edu/files/virtual-library/Documents/my_daughter_has_borderline_personality_disorder.pdf)

### **Table of Contents Xj600 Engine Diagram**

1. Understanding the eBook Xj600 Engine Diagram
  - The Rise of Digital Reading Xj600 Engine Diagram
  - Advantages of eBooks Over Traditional Books
2. Identifying Xj600 Engine Diagram
  - Exploring Different Genres
  - Considering Fiction vs. Non-Fiction
  - Determining Your Reading Goals
3. Choosing the Right eBook Platform
  - Popular eBook Platforms
  - Features to Look for in an Xj600 Engine Diagram

- User-Friendly Interface
- 4. Exploring eBook Recommendations from Xj600 Engine Diagram
  - Personalized Recommendations
  - Xj600 Engine Diagram User Reviews and Ratings
  - Xj600 Engine Diagram and Bestseller Lists
- 5. Accessing Xj600 Engine Diagram Free and Paid eBooks
  - Xj600 Engine Diagram Public Domain eBooks
  - Xj600 Engine Diagram eBook Subscription Services
  - Xj600 Engine Diagram Budget-Friendly Options
- 6. Navigating Xj600 Engine Diagram eBook Formats
  - ePub, PDF, MOBI, and More
  - Xj600 Engine Diagram Compatibility with Devices
  - Xj600 Engine Diagram Enhanced eBook Features
- 7. Enhancing Your Reading Experience
  - Adjustable Fonts and Text Sizes of Xj600 Engine Diagram
  - Highlighting and Note-Taking Xj600 Engine Diagram
  - Interactive Elements Xj600 Engine Diagram
- 8. Staying Engaged with Xj600 Engine Diagram
  - Joining Online Reading Communities
  - Participating in Virtual Book Clubs
  - Following Authors and Publishers Xj600 Engine Diagram
- 9. Balancing eBooks and Physical Books Xj600 Engine Diagram
  - Benefits of a Digital Library
  - Creating a Diverse Reading Collection Xj600 Engine Diagram
- 10. Overcoming Reading Challenges
  - Dealing with Digital Eye Strain
  - Minimizing Distractions
  - Managing Screen Time
- 11. Cultivating a Reading Routine Xj600 Engine Diagram
  - Setting Reading Goals Xj600 Engine Diagram

- Carving Out Dedicated Reading Time
- 12. Sourcing Reliable Information of Xj600 Engine Diagram
  - Fact-Checking eBook Content of Xj600 Engine Diagram
  - Distinguishing Credible Sources
- 13. Promoting Lifelong Learning
  - Utilizing eBooks for Skill Development
  - Exploring Educational eBooks
- 14. Embracing eBook Trends
  - Integration of Multimedia Elements
  - Interactive and Gamified eBooks

### **Xj600 Engine Diagram Introduction**

Free PDF Books and Manuals for Download: Unlocking Knowledge at Your Fingertips In today's fast-paced digital age, obtaining valuable knowledge has become easier than ever. Thanks to the internet, a vast array of books and manuals are now available for free download in PDF format. Whether you are a student, professional, or simply an avid reader, this treasure trove of downloadable resources offers a wealth of information, conveniently accessible anytime, anywhere. The advent of online libraries and platforms dedicated to sharing knowledge has revolutionized the way we consume information. No longer confined to physical libraries or bookstores, readers can now access an extensive collection of digital books and manuals with just a few clicks. These resources, available in PDF, Microsoft Word, and PowerPoint formats, cater to a wide range of interests, including literature, technology, science, history, and much more. One notable platform where you can explore and download free Xj600 Engine Diagram PDF books and manuals is the internet's largest free library. Hosted online, this catalog compiles a vast assortment of documents, making it a veritable goldmine of knowledge. With its easy-to-use website interface and customizable PDF generator, this platform offers a user-friendly experience, allowing individuals to effortlessly navigate and access the information they seek. The availability of free PDF books and manuals on this platform demonstrates its commitment to democratizing education and empowering individuals with the tools needed to succeed in their chosen fields. It allows anyone, regardless of their background or financial limitations, to expand their horizons and gain insights from experts in various disciplines. One of the most significant advantages of downloading PDF books and manuals lies in their portability. Unlike physical copies, digital books can be stored and carried on a single device, such as a tablet or smartphone, saving valuable space and weight. This convenience makes it possible for readers to have their entire library at their fingertips, whether they are commuting, traveling, or simply enjoying a lazy afternoon at home. Additionally,

digital files are easily searchable, enabling readers to locate specific information within seconds. With a few keystrokes, users can search for keywords, topics, or phrases, making research and finding relevant information a breeze. This efficiency saves time and effort, streamlining the learning process and allowing individuals to focus on extracting the information they need. Furthermore, the availability of free PDF books and manuals fosters a culture of continuous learning. By removing financial barriers, more people can access educational resources and pursue lifelong learning, contributing to personal growth and professional development. This democratization of knowledge promotes intellectual curiosity and empowers individuals to become lifelong learners, promoting progress and innovation in various fields. It is worth noting that while accessing free Xj600 Engine Diagram PDF books and manuals is convenient and cost-effective, it is vital to respect copyright laws and intellectual property rights. Platforms offering free downloads often operate within legal boundaries, ensuring that the materials they provide are either in the public domain or authorized for distribution. By adhering to copyright laws, users can enjoy the benefits of free access to knowledge while supporting the authors and publishers who make these resources available. In conclusion, the availability of Xj600 Engine Diagram free PDF books and manuals for download has revolutionized the way we access and consume knowledge. With just a few clicks, individuals can explore a vast collection of resources across different disciplines, all free of charge. This accessibility empowers individuals to become lifelong learners, contributing to personal growth, professional development, and the advancement of society as a whole. So why not unlock a world of knowledge today? Start exploring the vast sea of free PDF books and manuals waiting to be discovered right at your fingertips.

### **FAQs About Xj600 Engine Diagram Books**

How do I know which eBook platform is the best for me? Finding the best eBook platform depends on your reading preferences and device compatibility. Research different platforms, read user reviews, and explore their features before making a choice. Are free eBooks of good quality? Yes, many reputable platforms offer high-quality free eBooks, including classics and public domain works. However, make sure to verify the source to ensure the eBook credibility. Can I read eBooks without an eReader? Absolutely! Most eBook platforms offer webbased readers or mobile apps that allow you to read eBooks on your computer, tablet, or smartphone. How do I avoid digital eye strain while reading eBooks? To prevent digital eye strain, take regular breaks, adjust the font size and background color, and ensure proper lighting while reading eBooks. What the advantage of interactive eBooks? Interactive eBooks incorporate multimedia elements, quizzes, and activities, enhancing the reader engagement and providing a more immersive learning experience. Xj600 Engine Diagram is one of the best book in our library for free trial. We provide copy of Xj600 Engine Diagram in digital format, so the resources that you

find are reliable. There are also many Ebooks of related with Xj600 Engine Diagram. Where to download Xj600 Engine Diagram online for free? Are you looking for Xj600 Engine Diagram PDF? This is definitely going to save you time and cash in something you should think about. If you trying to find then search around for online. Without a doubt there are numerous these available and many of them have the freedom. However without doubt you receive whatever you purchase. An alternate way to get ideas is always to check another Xj600 Engine Diagram. This method for see exactly what may be included and adopt these ideas to your book. This site will almost certainly help you save time and effort, money and stress. If you are looking for free books then you really should consider finding to assist you try this. Several of Xj600 Engine Diagram are for sale to free while some are payable. If you arent sure if the books you would like to download works with for usage along with your computer, it is possible to download free trials. The free guides make it easy for someone to free access online library for download books to your device. You can get free download on free trial for lots of books categories. Our library is the biggest of these that have literally hundreds of thousands of different products categories represented. You will also see that there are specific sites catered to different product types or categories, brands or niches related with Xj600 Engine Diagram. So depending on what exactly you are searching, you will be able to choose e books to suit your own need. Need to access completely for Campbell Biology Seventh Edition book? Access Ebook without any digging. And by having access to our ebook online or by storing it on your computer, you have convenient answers with Xj600 Engine Diagram To get started finding Xj600 Engine Diagram, you are right to find our website which has a comprehensive collection of books online. Our library is the biggest of these that have literally hundreds of thousands of different products represented. You will also see that there are specific sites catered to different categories or niches related with Xj600 Engine Diagram So depending on what exactly you are searching, you will be able to choose ebook to suit your own need. Thank you for reading Xj600 Engine Diagram. Maybe you have knowledge that, people have search numerous times for their favorite readings like this Xj600 Engine Diagram, but end up in harmful downloads. Rather than reading a good book with a cup of coffee in the afternoon, instead they juggled with some harmful bugs inside their laptop. Xj600 Engine Diagram is available in our book collection an online access to it is set as public so you can download it instantly. Our digital library spans in multiple locations, allowing you to get the most less latency time to download any of our books like this one. Merely said, Xj600 Engine Diagram is universally compatible with any devices to read.

### **Find Xj600 Engine Diagram :**

[moriah plath anorexic](#)

**music notes in word**

[my daughter has borderline personality disorder](#)



**my first book of knowledge**

**my dear little one**

**my world margaret wise brown**

~~mtel english practice test~~

*my dad book pdf*

~~moms on call daylight savings~~

**most illustrator projects will either be**

*muscle structure labeling*

*mr invincible she hulk*

*molar solubility from concentration*

~~my dark vanessa movie cast~~

~~motorola professional radio~~

**Xj600 Engine Diagram :**