

SONY

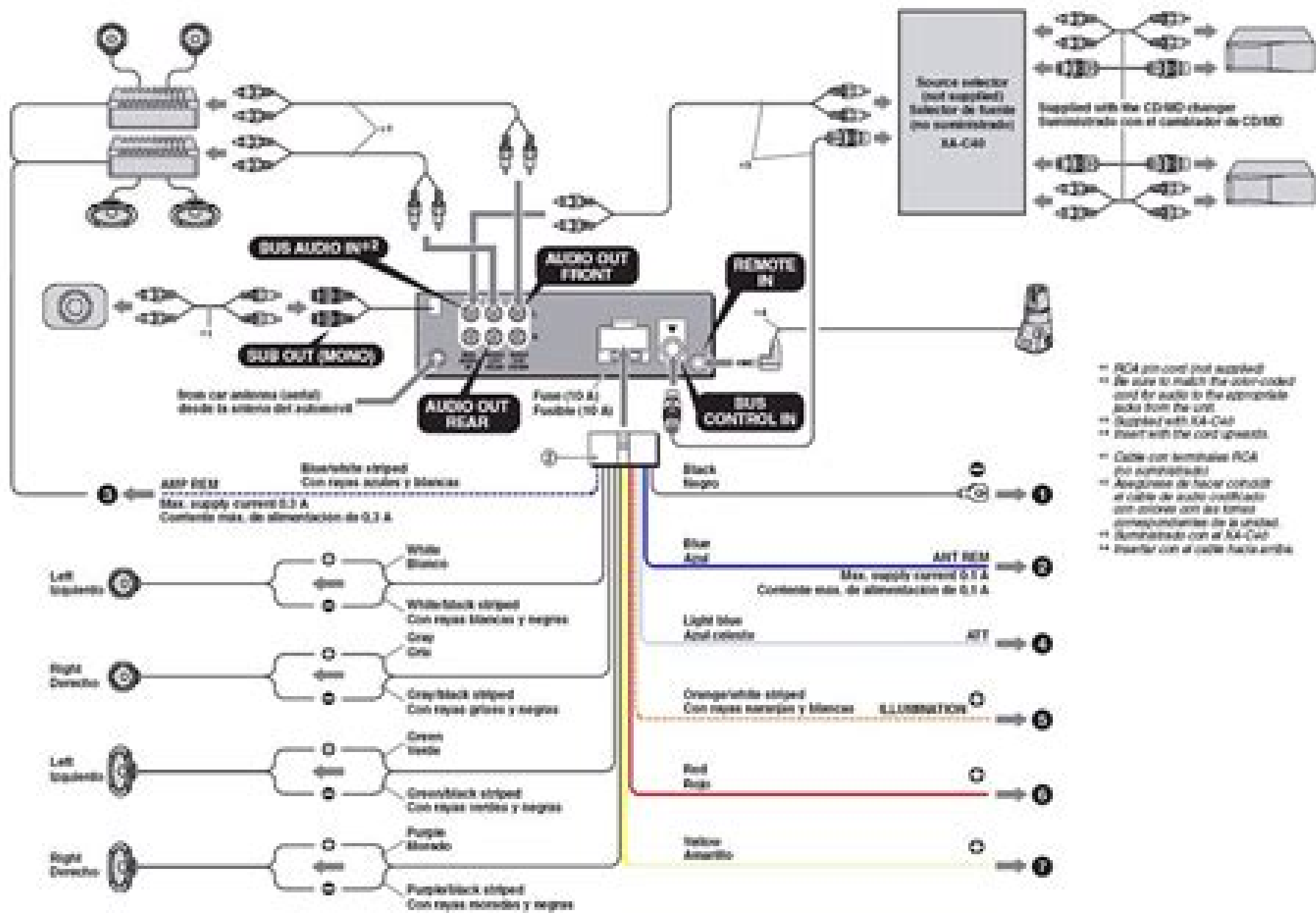

- RCA pin cord (not supplied)
- Be sure to match the color-coded cord for audio to the appropriate jack from the unit.
- Supplied with SA-C40
- Insert with the cord upwards.
- Cable con terminales RCA (no suministrado)
- Asegúrese de hacer coincidir el cable de audio con el conector correspondiente de la unidad.
- Suministrado con el SA-C40
- Insertar con el cable hacia arriba.

Sony Portable Media Storage User Manual

Michael Freeman



Sony Portable Media Storage User Manual

Portable Moving Images Ricardo Cedeño Montaña, 2017-08-21 This media history explores a series of portable small cameras playback devices and storage units that have made the production of film and video available to everyone Covering several storage formats from 8mm films of the 1900s through the analogue videotapes of the 1970s to the compression algorithms of the 2000s this work examines the effects that the shrinkage of complex machines media formats and processing operations has had on the dissemination of moving images Using an archaeological approach to technical standards of media the author provides a genealogy of portable storage formats for film analog video and digitally encoded video This book is a step forward in decoding the storage media formats which up to now have been the domain of highly specialised technicians

Multimedia Security Handbook Borko Furht, Darko Kirovski, 2004-12-28 Intellectual property owners who exploit new ways of reproducing distributing and marketing their creations digitally must also protect them from piracy *Multimedia Security Handbook* addresses multiple issues related to the protection of digital media including audio image and video content This volume examines leading edge multimedia security

Digital Photographer's Guide to Media Management Tim Grey, 2006 This must have guide presents smart solutions to difficulties of media management It examines all the hardware discusses archiving gives the lowdown on portable hard drives input and output devices digital media cards and advanced systems Learn software fundamentals and see how the Internet can become a versatile tool for sharing displaying and selling photography

Handbook of Forensic Photography Sanford Weiss, 2022-06-20 *Handbook of Forensic Photography* is the most comprehensive definitive reference for the use of photography in the capture and presentation of forensic evidence The intent is to inform the reader about the most complete and up to date methods to capture and reproduce images that most accurately represent the evidence With the rise in importance of forensic science crime and accident scene documentation has likewise increased in importance not the least of which has been forensic photography The need to use accepted practice and protocols to guarantee the authenticity of images for evidence documentation is paramount for using it in court And as with any discipline there is an art to the science of forensic photography Contributing authors from various backgrounds each experts in their field have provided numerous case examples best practices and recommendations for recognizing recording and preserving evidence using cameras and the latest digital image technology including video and other imaging technologies Chapters present such topics as videography drone photography underwater photography crime scene photography autopsy photographs fire documentation forensic odontology and more The book closes with coverage of courtroom displays presenting imaging evidence and expert witness testimony in the courtroom *Handbook of Forensic Photography* is a must have reference for experienced crime scene photographers death and crime scene investigators police and forensic professionals including medical examiners odontologists engineers and forensic

anthropologists who frequently need to capture investigative photographs in the course of investigations

The Handbook of Photonics Mool C. Gupta, John Ballato, 2018-10-03 Reflecting changes in the field in the ten years since the publication of the first edition *The Handbook of Photonics* Second Edition explores recent advances that have affected this technology In this new updated second edition editor Mool Gupta is joined by John Ballato strengthening the handbook with their combined knowledge and the continued contributions of world class researchers New in the Second Edition Information on optical fiber technology and the economic impact of photonics Coverage of emerging technologies in nanotechnology Sections on optical amplifiers and polymeric optical materials The book covers photonics materials devices and systems respectively An introductory chapter new to this edition provides an overview of photonics technology innovation and economic development Resting firmly on the foundation set by the first edition this new edition continues to serve as a source for introductory material and a collection of published data for research and training in this field making it the reference of first resort

The Filmmaker's Handbook Steven Ascher, Edward Pincus, 2007-09-04 2008 Edition The authoritative guide to funding preparing shooting lighting editing finishing and distributing your film or video Widely acknowledged as the bible of film and video production and used in courses around the world this indispensable guide to making movies is now updated with the latest advances in high definition formats For students and teachers the professional and the novice filmmaker this clear and comprehensive handbook remains the reliable reference to all aspects of moviemaking Techniques for making narrative documentary corporate experimental and feature films Working with high definition and standard definition digital video formats including DV HD and HDV Extensive coverage of video editing with the latest nonlinear editing systems Thorough grounding in lenses lighting sound recording and sound editing The business aspects of financing and producing movies Written by filmmakers for filmmakers this book will give you the skills you need to take your dreams from script to screen

Pro Digital Photographer's Handbook Michael Freeman, 2005 Michael Freeman has a well deserved reputation for effectively explaining the concepts behind digital picture taking to a variety of audiences Here he turns his attention to the professionals and advanced hobbyists who are making the move from traditional to digital and want help mastering the technology and meeting their clients new requirements Freeman thoroughly answers the most frequently asked questions about the basics of digital capture from cameras and computers to storage options printers and scanners Photographers will learn the different file formats and how to save images for print or publishing on the web They ll explore valuable software tools and basic image processing programs that fix common problems and see how to improve pictures using an assortment of cropping and filtering techniques The smart detailed advice will give photographers confidence as they enter this new digital world

CNET's Guide to Digital Photography TechRepublic, Incorporated, 2002-12

National Association of Broadcasters Engineering Handbook Garrison C. Cavell, 2017-07-28 The NAB Engineering Handbook is the definitive resource for broadcast engineers It provides in depth information about each aspect of the broadcast chain from audio and

video contribution through an entire broadcast facility all the way to the antenna New topics include Ultra High Definition Television Internet Radio Interfacing and Streaming ATSC 3.0 Digital Audio Compression Techniques Digital Television Audio Loudness Management and Video Format and Standards Conversion Important updates have been made to incumbent topics such as AM Shortwave FM and Television Transmitting Systems Studio Lighting Cameras and Principles of Acoustics The big picture comprehensive nature of the NAB Engineering Handbook will appeal to all broadcast engineers everyone from broadcast chief engineers who need expanded knowledge of all the specialized areas they encounter in the field to technologists in specialized fields like IT and RF who are interested in learning about unfamiliar topics Chapters are written to be accessible and easy to understand by all levels of engineers and technicians A wide range of related topics that engineers and technical managers need to understand are covered including broadcast documentation FCC practices technical standards security safety disaster planning facility planning project management and engineering management

The Digital Consumer Technology Handbook Amit Dhir, 2004-04-30 The consumer electronics market has never been as awash with new consumer products as it has over the last couple of years The devices that have emerged on the scene have led to major changes in the way consumers listen to music access the Internet communicate watch videos play games take photos operate their automobiles even live Digital electronics has led to these leaps in product development enabling easier exchange of media cheaper and more reliable products and convenient services This handbook is a much needed comprehensive engineering guide to the dynamic world of today's digital consumer electronics It provides complete details on key enabling technologies standards delivery and reception systems products appliances and networking systems Each chapter follows a logical progression from a general overview of each device to market dynamics to the core technologies and components that make up that particular product The book thoroughly covers all of the key digital consumer product categories digital TV digital audio mobile communications devices gaming consoles DVD players PCs and peripherals display devices digital imaging devices web terminals and pads PDAs and other handhelds screenphones videophones telematics devices eBooks and readers and many other current and future products To receive a FREE daily newsletter on displays and consumer electronics go to <http://www.displaydaily.com> Surveys crucial engineering information for every digital consumer product category including cell phones digital TVs digital cameras PDAs and many more the only reference available to do so Has extremely broad market appeal to embedded systems professionals including engineers programmers engineering managers marketing and sales personnel 1 000 000 potential readers Helps engineers and managers make the correct design decisions based on real world data **HWM**, 2005-10 Singapore's leading tech magazine gives its readers the power to decide with its informative articles and in depth reviews *A Practical Guide to Digital Forensics Investigations* Darren R. Hayes, 2020-10-16 THE DEFINITIVE GUIDE TO DIGITAL FORENSICS NOW THOROUGHLY UPDATED WITH NEW TECHNIQUES TOOLS AND SOLUTIONS Complete practical coverage of both technical and investigative skills Thoroughly

covers modern devices networks and the Internet Addresses online and lab investigations documentation admissibility and more Aligns closely with the NSA Knowledge Units and the NICE Cybersecurity Workforce Framework As digital crime soars so does the need for experts who can recover and evaluate evidence for successful prosecution Now Dr Darren Hayes has thoroughly updated his definitive guide to digital forensics investigations reflecting current best practices for securely seizing extracting and analyzing digital evidence protecting the integrity of the chain of custody effectively documenting investigations and scrupulously adhering to the law so that your evidence is admissible in court Every chapter of this new Second Edition is revised to reflect newer technologies the latest challenges technical solutions and recent court decisions Hayes has added detailed coverage of wearable technologies IoT forensics 5G communications vehicle forensics and mobile app examinations advances in incident response and new iPhone and Android device examination techniques Through practical activities realistic examples and fascinating case studies you ll build hands on mastery and prepare to succeed in one of today s fastest growing fields LEARN HOW TO Understand what digital forensics examiners do the evidence they work with and the opportunities available to them Explore how modern device features affect evidence gathering and use diverse tools to investigate them Establish a certified forensics lab and implement best practices for managing and processing evidence Gather data online to investigate today s complex crimes Uncover indicators of compromise and master best practices for incident response Investigate financial fraud with digital evidence Use digital photographic evidence including metadata and social media images Investigate wearable technologies and other Internet of Things devices Learn new ways to extract a full fi le system image from many iPhones Capture extensive data and real time intelligence from popular apps Follow strict rules to make evidence admissible even after recent Supreme Court decisions *Moody's Industrial Manual* ,1997 Covering New York American regional stock exchanges international companies *Official Gazette of the United States Patent and Trademark Office* ,2005 **Maximum PC** ,2005-09 Maximum PC is the magazine that every computer fanatic PC gamer or content creator must read Each and every issue is packed with punishing product reviews insightful and innovative how to stories and the illuminating technical articles that enthusiasts crave **PC Mag** ,1997-05-06 PCMag.com is a leading authority on technology delivering Labs based independent reviews of the latest products and services Our expert industry analysis and practical solutions help you make better buying decisions and get more from technology

Complete CompTIA A+ Guide to PCs Cheryl A. Schmidt,2013-02-14 Master PC installation configuration repair maintenance and networking and fully prepare for the CompTIA A 220 801 and 220 802 exams This unique tutorial and study guide teaches the fundamentals of computer desktop and laptop installation configuration maintenance and networking with thorough instruction built on the CompTIA A 220 801 and 220 802 exam objectives Learn all the skills you need to become a certified professional and customer friendly technician using today s tools and technologies Every chapter opens with focused learning objectives and lists the exam objectives covered in that chapter To meet the learning objectives each

chapter includes detailed figures helpful Tech Tips explanations of key terms step by step instruction and complete coverage of every topic At the end of every chapter are comprehensive assessment tools including a summary review questions labs activities and exam tips Covers Both 2012 A Exams A 220 801 PC Hardware Networking Laptops Printers Operational Procedures A 220 802 Operating Systems Security Mobile Devices Troubleshooting Learn more quickly and thoroughly with all these study and review tools Learning Objectives provide the goals for each chapter Practical Tech Tips give real world PC repair knowledge Soft Skills information and activities in each chapter cover all the tools and skills you need to become a professional customer friendly technician in every category Review Questions including true false multiple choice matching fill in the blank and open ended questions assess your knowledge of the learning objectives More than 125 Lab Exercises enable you to link theory to practical experience Key Terms identify exam words and phrases associated with each topic Detailed Glossary clearly defines every key term Critical Thinking Activities in every chapter take you beyond the facts to complete comprehension of topics Chapter Summary provides a recap of key concepts See Special Offer in Back of Book to save 70% on the CompTIA A Cert Guide Deluxe Edition Premium Edition eBook and Practice Test

David Busch's Sony Alpha a7R IV Guide to Digital Photography David D. Busch, 2019-12-16 David Busch's Sony Alpha a7R IV Guide to Digital Photography is the most comprehensive resource and reference for Sony's innovative 61 megapixel full frame mirrorless camera Capable of 10 frame per second bursts even at full resolution the a7R IV is fast enough for action photography and its 15 stop enhanced dynamic range delivers the image quality that the most demanding landscape or fine art photographer requires This camera's remarkable low light performance fast sensor based 567 point phase detect autofocus with real time face and eye tracking in both still and movie modes and improved 5 axis in body image stabilization the a7R IV has all the tools needed to take incredible images This book will show you how to master those features as you explore the world of digital photography and hone your creativity with your a7R IV Filled with detailed how to steps and full color illustrations David Busch's Sony Alpha a7R IV Guide to Digital Photography covers every feature of this camera in depth from taking your first photos through advanced details of setup exposure lens selection lighting and more and relates each feature to specific photographic techniques and situations Also included is the handy camera roadmap chapter an easy to use visual guide to the camera's features and controls Learn when to use every option and more importantly when not to use them by following the author's recommended settings for each menu entry With best selling photographer and mentor David Busch as your guide you'll quickly have full creative mastery of your camera's capabilities whether you're shooting on the job as an advanced enthusiast exploring full frame photography for the first time or are just out for fun Start building your knowledge and confidence while bringing your vision to light with the Sony a7R IV

LAN Times Guide to Multimedia Networking Nancy Cox, Charles T. Manley, Francis Chea, 1995 If you're a network administrator or not this book will take you from the basics of multimedia networking to advanced topics and beyond It helps users plan and make proper decisions by discussing

issues and offering advice on building and maintaining networks that use multimedia Topics include file formats multimedia presentations transmission and compression techniques **HWM** ,2006-04 Singapore s leading tech magazine gives its readers the power to decide with its informative articles and in depth reviews

MILITARY FOOD ENGINEERING and RATION ... Performance Op- timization research seeks to identify and validate, through sound sci- ence, dietary supplements and phytonutrients,as well as incorporation in ... Military Food Engineering and Ration Technology Systematic synthesis of U.S. military's food product development, processing, packaging, testing, and distribution methods; Provides technical data for ... Military Food Engineering and Ration Technology The book offers new data on numerous technologies used to solve problems such as nutrient densification, lightweighting, novel thermal processing, and long-term ... Military Food Engineering and Ration Technology Systematic synthesis of U.S. military's food product development, processing, packaging, testing, and distribution methods Provides technical data for ... Military Food Engineering and Ration Technology The new Food Acceptance Branch revolutionized sensory and consumer research on military rations. Details are provided on concepts and methods for testing ... Military food engineering and ration technology Military food engineering and ration technology · Combat Feeding Directorate (U.S.) · Food engineers · Food engineers United States · Operational rations (... Military Food Engineering and Ration Technology The book offers new data on numerous technologies used to solve problems such as nutrient densification, lightweighting, novel thermal processing, and long-term ... Military Food Engineering and Ration Technology [Hardback] The book offers new data on numerous technologies used to solve problems such as nutrient densification, lightweighting, novel thermal processing, and long-term ... Military Food Engineering and Ration Technology Systematic synthesis of U.S. military's food product development, processing, packaging, testing, and distribution methods · Provides technical data for ... Military Food Engineering and Ration Technology Military Food Engineering and Ration Technology · 1. An Overview of U.S. Military Field Feeding and Combat Rations · 2. Thermal Processing of Rations · 3. Emerging ... Earth Science - 1st Edition - Solutions and Answers Our resource for Earth Science includes answers to chapter exercises, as well as detailed information to walk you through the process step by step. With Expert ... McDougal Littell Earth Science Textbook Solutions & ... Get your McDougal Littell Earth Science homework done with Quizlet! Browse through thousands of step-by-step solutions to end-of-chapter ... Earth Science New York Regents Review Answer Key ... Amazon.com: Earth Science New York Regents Review Answer Key Grades 9-12 (Mcdougal Littell Earth Science): 9780618798117: Mcdougal Littel: Books. Earth Science Textbook Answers Browse bartleby's library of Earth Science textbooks to find answers to your specific homework questions. Have Earth Science homework questions? Mcdougal Littell Earth Science Test Book with Answers (03 ... Mcdougal Littell Earth Science Test Book with Answers (03,05) used for 0618499385 (1bk) · \$69.00 USD · Share this item by email. Earth Science Assessments

Answer Key, 5th ed. Nov 15, 2019 — Provides over-print answers as teachers assess their students' knowledge and understanding of key concepts. Physical science interactive science textbook answers Interactive Textbook Answer Key 33 Earth Science Earth Science Answer ... Mcdougal Littell Earth Science Textbook Answers. Jan 09, 2022 ... Physical science interactive science textbook answers - iwd3.de Mcdougal Littell Earth Science Textbook Answers. LearnDataSci is reader-supported. Standards-aligned science lessons — Cover core standards in 1-2 hours of ... Holt Earth Science Textbook Answers Holt Earth Science Textbook Answers. Holt Earth Science Textbook Answers Discover all in Bartleby's homework solutions you need for the textbooks you have. Chili Cook Off Rules and Free Score Sheet Chili cook off rules and free score sheet, plus printable chili name cards, and ideas for how to host your own chili cook off. Chili Cook-Off Score sheet Chili Cook-Off Score sheet. Judges' Score Sheet. Score: 0 - 10 (10 is highest). Chili #: _____. Criteria. Criteria Thought Starters. Score. Taste. Chili should ... Chili Score Card Printable Chili Cook-Off Scorecard, Cook Off Competition Ranking Card, NO EDITING Required, Just Download & Print. (809). Sale Price \$3.60 ... chili cookoff scorecard CHILI COOKOFF SCORECARD. NAME: RATE ON A SCALE OF 1 5, 5 BEING THE BEST. AROMA: CREATIVITY: FLAVOR: TEXTURE: PRESENTATION:.. 7.7K+ Free Templates for 'Chili cook off scorecard template' Create free chili cook off scorecard template flyers, posters, social media graphics and videos in minutes. Choose from 7750+ eye-catching templates to wow ... Chili Cook Off Rules and Free Score Sheet Jan 5, 2017 - Chili cook off rules and free score sheet, plus printable chili name cards, and ideas for how to host your own chili cook off. Printable Chili Cook-Off Score Card Judges of a chili cookoff can use this set of note cards to assess the qualities of homemade chili based on appearance, smell, texture, and other factors. Hosting a Chili Cook-Off in 5 Easy Steps with Printables Jan 24, 2014 — Chili Cook Off Voting Ballots - Chili Score Cards - Chili - Rating Cards - Chili Contest - Annual Chili Cook Off-Printable - First to Third. Cookoff Score Cards Instant Download Chili Cook-Off Tasting and Rating Scorecard - White Background. (27). \$6.00.

Embark on a transformative journey with Written by is captivating work, Grab Your Copy of **Sony Portable Media Storage User Manual** . This enlightening ebook, available for download in a convenient PDF format , invites you to explore a world of boundless knowledge. Unleash your intellectual curiosity and discover the power of words as you dive into this riveting creation. Download now and elevate your reading experience to new heights .

https://offsite.creighton.edu/files/virtual-library/Documents/oops_design_questions.pdf

https://offsite.creighton.edu/files/virtual-library/Documents/original_hebrew_bible_pdf.pdf

https://offsite.creighton.edu/files/virtual-library/Documents/organizational_behavior_topics_for_research.pdf

Table of Contents Sony Portable Media Storage User Manual

1. Understanding the eBook Sony Portable Media Storage User Manual
 - The Rise of Digital Reading Sony Portable Media Storage User Manual
 - Advantages of eBooks Over Traditional Books
2. Identifying Sony Portable Media Storage User Manual
 - Exploring Different Genres
 - Considering Fiction vs. Non-Fiction
 - Determining Your Reading Goals
3. Choosing the Right eBook Platform
 - Popular eBook Platforms
 - Features to Look for in an Sony Portable Media Storage User Manual
 - User-Friendly Interface
4. Exploring eBook Recommendations from Sony Portable Media Storage User Manual
 - Personalized Recommendations

- Sony Portable Media Storage User Manual User Reviews and Ratings
- Sony Portable Media Storage User Manual and Bestseller Lists
- 5. Accessing Sony Portable Media Storage User Manual Free and Paid eBooks
 - Sony Portable Media Storage User Manual Public Domain eBooks
 - Sony Portable Media Storage User Manual eBook Subscription Services
 - Sony Portable Media Storage User Manual Budget-Friendly Options
- 6. Navigating Sony Portable Media Storage User Manual eBook Formats
 - ePub, PDF, MOBI, and More
 - Sony Portable Media Storage User Manual Compatibility with Devices
 - Sony Portable Media Storage User Manual Enhanced eBook Features
- 7. Enhancing Your Reading Experience
 - Adjustable Fonts and Text Sizes of Sony Portable Media Storage User Manual
 - Highlighting and Note-Taking Sony Portable Media Storage User Manual
 - Interactive Elements Sony Portable Media Storage User Manual
- 8. Staying Engaged with Sony Portable Media Storage User Manual
 - Joining Online Reading Communities
 - Participating in Virtual Book Clubs
 - Following Authors and Publishers Sony Portable Media Storage User Manual
- 9. Balancing eBooks and Physical Books Sony Portable Media Storage User Manual
 - Benefits of a Digital Library
 - Creating a Diverse Reading Collection Sony Portable Media Storage User Manual
- 10. Overcoming Reading Challenges
 - Dealing with Digital Eye Strain
 - Minimizing Distractions
 - Managing Screen Time
- 11. Cultivating a Reading Routine Sony Portable Media Storage User Manual
 - Setting Reading Goals Sony Portable Media Storage User Manual
 - Carving Out Dedicated Reading Time
- 12. Sourcing Reliable Information of Sony Portable Media Storage User Manual
 - Fact-Checking eBook Content of Sony Portable Media Storage User Manual

- Distinguishing Credible Sources
- 13. Promoting Lifelong Learning
 - Utilizing eBooks for Skill Development
 - Exploring Educational eBooks
- 14. Embracing eBook Trends
 - Integration of Multimedia Elements
 - Interactive and Gamified eBooks

Sony Portable Media Storage User Manual Introduction

Sony Portable Media Storage User Manual Offers over 60,000 free eBooks, including many classics that are in the public domain. Open Library: Provides access to over 1 million free eBooks, including classic literature and contemporary works. Sony Portable Media Storage User Manual Offers a vast collection of books, some of which are available for free as PDF downloads, particularly older books in the public domain. Sony Portable Media Storage User Manual : This website hosts a vast collection of scientific articles, books, and textbooks. While it operates in a legal gray area due to copyright issues, its a popular resource for finding various publications. Internet Archive for Sony Portable Media Storage User Manual : Has an extensive collection of digital content, including books, articles, videos, and more. It has a massive library of free downloadable books. Free-eBooks Sony Portable Media Storage User Manual Offers a diverse range of free eBooks across various genres. Sony Portable Media Storage User Manual Focuses mainly on educational books, textbooks, and business books. It offers free PDF downloads for educational purposes. Sony Portable Media Storage User Manual Provides a large selection of free eBooks in different genres, which are available for download in various formats, including PDF. Finding specific Sony Portable Media Storage User Manual, especially related to Sony Portable Media Storage User Manual, might be challenging as theyre often artistic creations rather than practical blueprints. However, you can explore the following steps to search for or create your own Online Searches: Look for websites, forums, or blogs dedicated to Sony Portable Media Storage User Manual, Sometimes enthusiasts share their designs or concepts in PDF format. Books and Magazines Some Sony Portable Media Storage User Manual books or magazines might include. Look for these in online stores or libraries. Remember that while Sony Portable Media Storage User Manual, sharing copyrighted material without permission is not legal. Always ensure youre either creating your own or obtaining them from legitimate sources that allow sharing and downloading. Library Check if your local library offers eBook lending services. Many libraries have digital catalogs where you can borrow Sony Portable Media Storage User Manual eBooks for free, including popular titles. Online Retailers: Websites like Amazon, Google Books, or Apple Books often sell eBooks. Sometimes, authors or publishers offer promotions or free

periods for certain books. Authors Website Occasionally, authors provide excerpts or short stories for free on their websites. While this might not be the Sony Portable Media Storage User Manual full book, it can give you a taste of the authors writing style. Subscription Services Platforms like Kindle Unlimited or Scribd offer subscription-based access to a wide range of Sony Portable Media Storage User Manual eBooks, including some popular titles.

FAQs About Sony Portable Media Storage User Manual Books

How do I know which eBook platform is the best for me? Finding the best eBook platform depends on your reading preferences and device compatibility. Research different platforms, read user reviews, and explore their features before making a choice. Are free eBooks of good quality? Yes, many reputable platforms offer high-quality free eBooks, including classics and public domain works. However, make sure to verify the source to ensure the eBook credibility. Can I read eBooks without an eReader? Absolutely! Most eBook platforms offer web-based readers or mobile apps that allow you to read eBooks on your computer, tablet, or smartphone. How do I avoid digital eye strain while reading eBooks? To prevent digital eye strain, take regular breaks, adjust the font size and background color, and ensure proper lighting while reading eBooks. What the advantage of interactive eBooks? Interactive eBooks incorporate multimedia elements, quizzes, and activities, enhancing the reader engagement and providing a more immersive learning experience. Sony Portable Media Storage User Manual is one of the best book in our library for free trial. We provide copy of Sony Portable Media Storage User Manual in digital format, so the resources that you find are reliable. There are also many Ebooks of related with Sony Portable Media Storage User Manual. Where to download Sony Portable Media Storage User Manual online for free? Are you looking for Sony Portable Media Storage User Manual PDF? This is definitely going to save you time and cash in something you should think about.

Find Sony Portable Media Storage User Manual :

oops design questions

[original hebrew bible pdf](#)

[*organizational behavior topics for research*](#)

[operations manual sample pdf](#)

one page operating agreement pdf

[olelo no eau book pdf](#)

on the subjection of women

okk 5 axis

one time credit card authorization form

open secret definition

pa ebt payment dates

~~online internal medicine board review~~

paintless dent repair training cost

oracion al dormir

one month calisthenics workout

Sony Portable Media Storage User Manual :