

Montageanleitung  
 Montageinstructions  
 Instrucciones de montaje  
 Installatiehandleiding  
 Инструкция по монтажу

Partnr.: 022173

HONDA CR-V



Ball code: 95-800-2177



EC R43  
nr. 01-000

Type number: 022173



1900 kg



1500 kg



70 kg

D  
max  
min

4,28 m



© BOSAL Partnr. 24

Date: 13-02-2008  
Rev. nr. 01

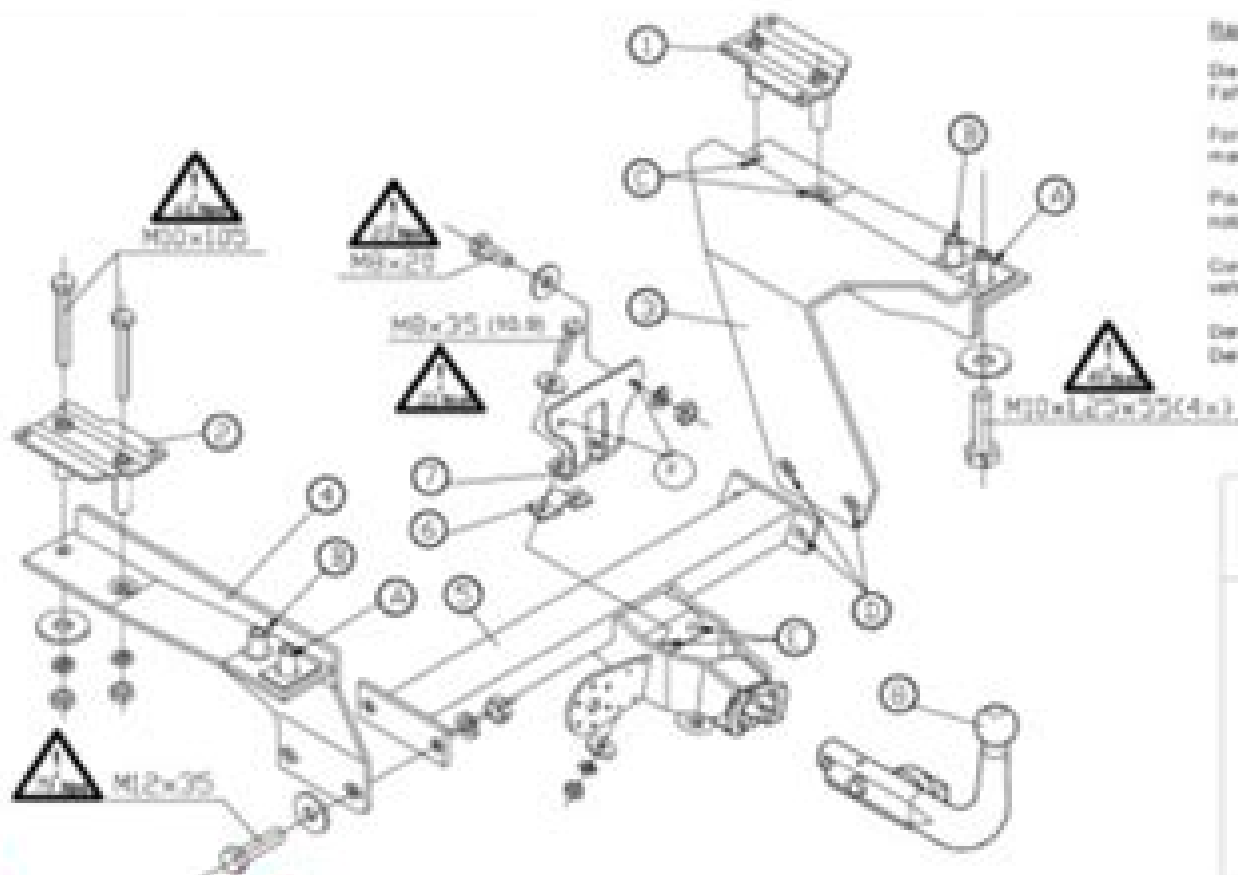

Banking en draai voor de wielassen van uw wagen niet meer.

Demonteer de wielassen van het voertuig vóór de in het voertuigpapiertje of in de gebruikershandleiding vermelde.

For the max. trailer weight of your car please refer to the owner's manual or your car homologation documents.

Pour connaître le poids maximal autorisé pour votre véhicule consultez le notice d'utilisation de votre véhicule ou la carte grise.

Consulte a su distribuidor sobre el peso máximo que puede remolcar su vehículo.

Dees behuuder of hunn spijer dien en den heep ditte veeg ofter deventing.

Montagevoorspraken  
Montageanleitung  
Practical parts

Material de fixation part  
Partes incluidas  
Montagevoorspraken



2x M10x125 (10-8)  
2x M8x25  
4x M10x125  
4x M10x125x40  
4x M10x20



4x M8  
4x M10  
4x M10



4x M8  
4x M10  
4x M10



4x M8  
4x M10  
4x M10



2x M8

**bosal**

# **Honda 2315 V Twin Manual**

**Editors of Haynes Manuals**



# Honda 2315 V Twin Manual

**Honda VT1100 Shadow V-twins Owners Workshop Manual** Mike Stubblefield, John Harold Haynes, 1999 Whether the reader has simple maintenance or a complete engine rebuild in mind he or she can rest assured that there s a Haynes manual for just above every popular domestic and import car truck and motorcycle By conducting complete tear downs and rebuilds the staff at Haynes Publishing has discovered all the problems owners will find when repairing or rebuilding their vehicles By documenting each process with hundreds of illustrations and step by step instructions that show the exact order of assembly Haynes manuals make every step easy to follow

**Honda CX500 V-Twin Owners Workshop Manual ...** Mansur Darlington, 1979 *Honda Crv 97 on* Jeremy Churchill, RM. Jex, 2008-12-01 Honda CR V Mk II models Does NOT cover Mk I range 97 01 or Mk III range introduced for 2007 Petrol 2 0 litre 1998cc i VTEC Diesel 2 2 litre 2204cc i CDTi

**Honda VT600 and VT750 Shadow V-twins Owners Workshop Manual** Mike Stubblefield, John Harold Haynes, 2002-08-16

**Honda Civic & CR-V Automotive Repair Manual** Robert Phillip Maddox, John Harold Haynes, 2008 Haynes offers the best coverage for cars trucks vans SUVs and motorcycles on the market today Each manual contains easy to follow step by step instructions linked to hundreds of photographs and illustrations Included in every manual troubleshooting section to help identify specific problems tips that give valuable short cuts to make the job easier and eliminate the need for special tools notes cautions and warnings for the home mechanic color spark plug diagnosis and an easy to use index

Honda VFR750 & 700 V-fours Owners Workshop Manual Haynes Publications, Incorporated, Jeremy Churchill, Mark Coombs, 1995 Haynes disassembles every subject vehicle and documents every step with thorough instructions and clear photos Haynes repair manuals are used by the pros but written for the do it yourselfer

**Honda Service Manual 88-89 VTR, VRT250**, 1988

**Honda Shadow VT600 & 750 '88 to '14** Editors of Haynes Manuals, 2016-07-15 Complete coverage for your Honda Shadow VT600 and VT750 covering 600cc and 750cc from 1988 thru 2014 Routine Maintenance and servicing Tune up procedures Engine clutch and transmission repair Cooling system Fuel and exhaust Ignition and electrical systems Brakes wheels and tires Steering suspension and final drive Frame and bodywork Wiring diagrams Reference Section With a Haynes manual you can do it yourself from simple maintenance to basic repairs Haynes writes every book based on a complete teardown of the vehicle We learn the best ways to do a job and that makes it quicker easier and cheaper for you Our books have clear instructions and hundreds of photographs that show each step Whether you re a beginner or a pro you can save big with Haynes Step by step procedures Easy to follow photos Complete troubleshooting section Valuable short cuts Color spark plug diagnosis

Honda VT1100C3w Shop Manual Honda Motor Co., Ltd, 1997 This manual describes the service procedures for the VT1100C3

**Honda Civic & CR-V Automotive Repair Manual** Jeff Killingsworth, John Harold

Haynes, 2016 **Chilton's Honda Civic & CR-V, 2001-10 Repair Manual** Robert Phillip Maddox, 2010 Covers U S and

Canadian models of Honda Civic 2001 through 2010 and Honda CR V 2002 through 2009 does not include information specific to CNG or hybrid models *Honda Service Manual 86-87 TR200 Fatcat*, 1986 *Honda Twinstar, Rebel 250 & Nighthawk 250, 1978-2016 Clymer Manual* Clymer Publications, 2020-02-25 With the help of the Clymer Honda Twinstar Rebel 250 Nighthawk 250 1978 2016 Manual in your toolbox you will be able to maintain service and repair your Honda motorcycle to extend its life for years to come Clymer manuals are very well known for their thorough and comprehensive nature This manual is loaded with step by step procedures along with detailed photography exploded views charts and diagrams to enhance the steps associated with a service or repair task This Clymer manual is organized by subsystem with procedures grouped together for specific topics such as front suspension brake system engine and transmission It includes color wiring diagrams The language used in this Clymer repair manual is targeted toward the novice mechanic but is also very valuable for the experienced mechanic The service manual by Clymer is an authoritative piece of DIY literature and should provide you the confidence you need to get the job done and save money too *Honda NTV600 Revere, NTV650 & NTV650V Deauville '88 to '05* Editors of Haynes Manuals, 2016-06-15 Complete coverage for your Honda NTV600 Revere NTV650 and NT650V 1988 thru 2005 Routine Maintenance and servicing Tune up procedures Engine clutch and transmission repair Cooling system Fuel and exhaust Ignition and electrical systems Brakes wheels and tires Steering suspension and final drive Frame and bodywork Wiring diagrams Reference Section With a Haynes manual you can do it yourself from simple maintenance to basic repairs Haynes writes every book based on a complete teardown of the vehicle We learn the best ways to do a job and that makes it quicker easier and cheaper for you Our books have clear instructions and hundreds of photographs that show each step Whether you re a beginner or a pro you can save big with Haynes Step by step procedures Easy to follow photos Complete troubleshooting section Valuable short cuts Color spark plug diagnosis [Honda Twins Owners Workshop Manual](#) Jeffrey Robert Clew, 1975 [Honda Common Service Manual](#) American Honda Motor Company, 1990 **Honda Shadow VT600 & 750 '88 to '09** Editors of Haynes Manuals, 2015-07-01 Complete coverage for your Honda Shadow VT600 and VT750 covering 600cc and 750cc from 1988 thru 2009 Routine Maintenance and servicing Tune up procedures Engine clutch and transmission repair Cooling system Fuel and exhaust Ignition and electrical systems Brakes wheels and tires Steering suspension and final drive Frame and bodywork Wiring diagrams Reference Section With a Haynes manual you can do it yourself from simple maintenance to basic repairs Haynes writes every book based on a complete teardown of the motorcycle We learn the best ways to do a job and that makes it quicker easier and cheaper for you Our books have clear instructions and hundreds of photographs that show each step Whether you re a beginner or a pro you can save big with Haynes Step by step procedures Easy to follow photos Complete troubleshooting section Valuable short cuts Model history and pre ride checks in color Color spark plug diagnosis and wiring diagrams Tools workshop tips section in color **Honda NE/NB50 Vision & SA50 Vision Met-in Owners Workshop Manual** Pete Shoemark, Penny Cox, 1993

**Honda NE/NB50 Vision & SA50 Vision Met-in Owners Workshop Manual** Pete Shoemark,Penny Cox,1992  
**Honda CX/GL 500 & 650 V-Twins Owners Workshop Manual** Jeremy Churchill,1987

**boş oda 2 İlk kurgu 2008 türkçe fragman** - Dec 27 2021

web buranın ıssızdan öte müşterilerine akla gelmeyecek işkenceler yapmak için kurulmuş korkunç tuzaklarla dolu bir otel olduğundan haberleri yoktur Ölümcül bir kedi fare oyununda sıkışmış bulan üç genç arkadaş şimdi hayatta kalmak için savaşmak zorundadırlar film boş oda 2 İlk kurgu tarz ürpertici kaba

**chapter two krugman and obstfeld boston collage full pdf** - Mar 10 2023

web chapter two krugman and obstfeld boston collage 1 chapter two krugman and obstfeld boston collage international economics theory and policy krugman 10th krugman obstfeld melitz international economics krugman obstfeld melitz chapter 2 world trade an overview paul r krugman maurice obstfeld

**international economics theory and policy google books** - Jan 28 2022

web paul r krugman maurice obstfeld pearson addison wesley 2009 business economics 706 pages chapter 1 introduction part i international trade theory chapter 2 world trade an overview chapter 3 labor productivity and comparative advantage the ricardian model chapter 4 resources comparative advantage and income

*chapter two krugman and obstfeld boston collage* - Sep 04 2022

web applications with this new tenth edition the author team of nobel prize winning economist paul krugman renowned researcher maurice obstfeld and marc melitz of harvard university continues to set the standard for international economics courses this program provides a better teaching and learning experience

**chapter two krugman and obstfeld boston collage** - Feb 09 2023

web chapter two krugman and obstfeld boston collage krugman obstfeld melitz chapter 2 world trade an overview start studying ch 2 international trade krugman obstfeld meltz learn vocabulary terms and more with flashcards games and other study tools chapter two krugman and obstfeld boston collage krugman

chapter two krugman and obstfeld boston collage - May 12 2023

web krugman and obstfeld boston collage chapter 2 introduces students to international trade theory through the ricardian model of trade this model shows how trade arises when page 12 45 where to download chapter two krugman and obstfeld boston collageinstructor s manual krugman p and obstfeld m 2003 chapters

chapter two krugman and obstfeld boston collage pdf pdf - Jan 08 2023

web chapter two krugman and obstfeld boston collage pdf pages 2 10 chapter two krugman and obstfeld boston collage pdf upload donald n williamson 2 10 downloaded from cqa6 e4score com on september 4 2023 by donald n williamson learning

process emerging market economies and financial globalization

**chapter two krugman and obstfeld boston collage pdf** - Apr 11 2023

web apr 14 2023 chapter two krugman and obstfeld boston collage 2 8 downloaded from uniport edu ng on april 14 2023 by guest survey of the literature that attempts to identify these episodes third what are the real and financial sector implications of crises the paper briefly reviews the short and medium run implications of crises

*pdf chapter two krugman and obstfeld boston collage read free* - Jul 02 2022

web aug 16 2023 its about what you craving currently this chapter two krugman and obstfeld boston collage as one of the most working sellers here will completely be accompanied by the best options to review right here we have countless ebook chapter two krugman and obstfeld boston collage and collections to check out

*chapter two krugman and obstfeld boston collage* - Mar 30 2022

web feb 24 2023 kindly say the chapter two krugman and obstfeld boston collage is universally compatible with any devices to read principles of conflict economics charles h anderton 2019 04 25 provides comprehensive up to date coverage of the key themes and principles of conflict economics the state of economics the state of the world

**chapter two krugman and obstfeld boston collage pdf** - Jul 14 2023

web krugman and obstfeld provide a unified model of open economy macroeconomics based upon an asset market approach to exchange rate determination with a central role for expectations

[chapter two krugman and obstfeld boston collage](#) - Jun 13 2023

web vivid examples and clear explanations of paul krugman and robin wells with the ap expertise of margaret ray and david anderson in this exciting new edition of the ap text ray and anderson successfully marry krugman s engaging approach and captivating writing with content based on the college board s ap economics course

*chapter two krugman and obstfeld boston collage copy* - Apr 30 2022

web chapter two krugman and obstfeld boston collage krugman obstfeld melitz chapter 2 world trade an overview chapter two krugman and obstfeld boston collage chapter two krugman and obstfeld boston collage downloaded from brannacholann com by guest swanson layla chapter two krugman and obstfeld

**chapter two krugman and obstfeld boston collage** - Nov 06 2022

web jun 15 2023 chapter two krugman and obstfeld boston collage you could speedily download this chapter two krugman and obstfeld boston collage after getting deal in the course of them is this chapter two krugman and obstfeld boston collage that can be your ally get the chapter two krugman and obstfeld boston collage join that

**chapter two krugman and obstfeld boston collage** - Dec 07 2022

web access free chapter two krugman and obstfeld boston collage through a theory that rests on three simple principles the

first two a survivor principle that says that firms will

*krugman ch 2 ppt ppt slideshare* - Feb 26 2022

web jan 21 2014 krugman ch 2 ppt 1 chapter 2 economic models trade offs and trade krugman wells 2009 worth publishers  
1 of 31 2 what you will learn in this chapter why models simplified representations of reality play a crucial role in economics  
two simple but important models production possibility frontier circular flow

**pdf chapter two krugman and obstfeld boston collage read** - Aug 03 2022

web aug 16 2023 pdf chapter two krugman and obstfeld boston collage read free economic recovery brought psychological  
and political damage krugman business insider the u s economy a simpler understanding of two recent articles star tribune  
paul krugman and mohamed el erian are

**chapter two krugman and obstfeld boston collage pdf copy** - Oct 05 2022

web the proclamation as without difficulty as acuteness of this chapter two krugman and obstfeld boston collage pdf can be  
taken as skillfully as picked to act principles of conflict economics charles h anderton 2019 04 25 provides comprehensive up  
to date coverage of the key themes and principles of conflict economics

**ebook chapter two krugman and obstfeld boston collage** - Aug 15 2023

web chapter two krugman and obstfeld boston collage international trade theory and policy apr 29 2021 in the present text  
the author deals with both conventional and new approaches to trade theory and policy treating all important research topics  
in international economics and clarifying their mathematical intricacies

chapter two krugman and obstfeld boston collage download - Jun 01 2022

web kindly say the chapter two krugman and obstfeld boston collage is universally compatible with any devices to read  
chapter two krugman and obstfeld boston collage downloaded from finemeters fun by guest johns alani instructor s manual  
usp chapter two krugman and obstfeldaces pdf chapter two krugman and

**primary handbook for mallets whaley garwood amazon ca** - Feb 15 2023

web jan 1 2010 internationally acclaimed by today s leading teachers primary handbook for mallets i xylophone marimba  
vibes and bells is designed for the beginner of any age this method provides a complete introduction to mallet playing for  
private lessons o

**garwood whaley open library** - Mar 04 2022

web author of primary handbook for mallets primary handbook for timpani musical studies for the intermediate mallet player  
primary handbook for snare drum 4 mallet fundamentals ahrirang fundamental studies for mallets fundamental studies for  
*primary handbook for mallets garwood whaley reverb* - Jun 07 2022

web internationally acclaimed by today s leading teachers primary handbook for mallets xylophone marimba vibes and bells

is designed for the beginner of any age this method provides a complete introduction to mallet playing for private lessons or classroom use

*gia publications primary handbook for mallets* - May 18 2023

web description internationally acclaimed by today s leading teachers primary handbook for mallets xylophone marimba vibes and bells is designed for the beginner of any age this method provides a complete introduction to mallet playing for private lessons or classroom use categories drum percussion publications keyboard percussion

primary handbook for mallets by garwood whaley open library - Jun 19 2023

web dec 26 2021 primary handbook for mallets by garwood whaley 2002 leonard corporation hal edition in english

*primary handbook for mallets book online audio garwood whaley* - Sep 10 2022

web internationally acclaimed by today s leading teachers primary handbook for mallets xylophone marimba vibes and bells is designed for the beginner of any age this method provides a complete introduction to mallet playing for private lessons or classroom use

**primary handbook for mallets whaley garwood** - Feb 03 2022

web mar 1 2000 internationally acclaimed by today s leading teachers primary handbook for mallets xylophone marimba vibes and bells is designed for the beginner of any age this method provides a complete introduction to mallet playing for

primary handbook for mallets amazon co uk whaley garwood - Jan 14 2023

web buy primary handbook for mallets by whaley garwood isbn 0073999170320 from amazon s book store everyday low prices and free delivery on eligible orders

*primary handbook for mallets by whaley garwood alibris* - May 06 2022

web internationally acclaimed by today s leading teachers primary handbook for mallets xylophone marimba vibes and bells is designed for the beginner of any age this method provides a complete introduction to mallet playing for private lessons or classroom use

**primary handbook for mallets meredith music percussion whaley** - Apr 05 2022

web primary handbook for mallets meredith music percussion whaley garwood on amazon com au free shipping on eligible orders primary handbook for mallets meredith music percussion

**primary handbook for mallets whaley garwood** - Aug 21 2023

web feb 1 2002 internationally acclaimed by today s leading teachers primary handbook for mallets xylophone marimba vibes and bells is designed for the beginner of any age this method provides a complete introduction to mallet playing for

whaley garwood author of primary handbook for mallets goodreads - Oct 11 2022

web whaley garwood is the author of primary handbook for mallets 4 00 avg rating 4 ratings 0 reviews published 2000



musical studies for the intermediat

**primary handbook for mallets sheet music plus** - Jan 02 2022

web internationally acclaimed by today s leading teachers primary handbook for mallets xylophone marimba vibes and bells is designed for the beginner of any age this method provides a complete introduction to mallet playing for private lessons or classroom use

*primary handbook for mallets sheet music plus* - Mar 16 2023

web internationally acclaimed by today s leading teachers primary handbook for mallets xylophone marimba vibes and bells is designed for the beginner of any age this method provides a complete introduction to mallet playing for private lessons or classroom use

**primary handbook for mallets by garwood whaley open library** - Dec 13 2022

web mar 1 2000 primary handbook for mallets by garwood whaley march 1 2000 hal leonard corporation edition paperback in english

*primary handbook for mallets garwood whaley google books* - Jul 20 2023

web internationally acclaimed by today s leading teachers primary handbook for mallets xylophone marimba vibes and bells is designed for the beginner of any age this method provides a

**primary handbook for mallets garwood whaley steve weiss** - Nov 12 2022

web internationally acclaimed by today s leading teachers primary handbook for mallets xylophone marimba vibes and bells by garwood whaley is designed for the beginner of any age this method provides a complete introduction to mallet playing for private lessons or classroom use

**primary handbook for mallets by garwood whaley composer** - Aug 09 2022

web internationally acclaimed by today s leading teachers primary handbook for mallets xylophone marimba vibes and bells is designed for the beginner of any age this method provides a complete introduction to mallet playing for private lessons or classroom use

**primary handbook for mallets amazon co uk whaley garwood** - Apr 17 2023

web buy primary handbook for mallets by whaley garwood isbn 9780634039249 from amazon s book store everyday low prices and free delivery on eligible orders

**garwood whaley primary handbook for mallets presto music** - Jul 08 2022

web sheet music for garwood whaley primary handbook for mallets buy online percussion xylophone marimba perc xylophone mar published by hal leonard meredith music composer whaley garwood

*full marks guide of samajik vigyan for class 7 hindi medium* - Sep 06 2022



ncert solutions for class 7 - Oct 19 2023

web sep 6 2023 class 7 social science ncert solutions

**amazon in bihar public service commission bpsc books** - May 02 2022

web bpsc bihar shikshak bahali teacher recruitment class 11 to 12 rajneeti vigyan political science 20 practice sets book in hindi 38 27500 bpsc tre bihar shikshak samajik vigyan social science for vishay gyan class 9 to 10 ncert scert based practice work book based on 120 questions pattern announced on 30 may by bpsc

**class 7 samajik vigyan social science ncert books in hindi** - May 14 2023

web july 24 2023 class 7 ncert books class 7 social science ncert books in hindi class 7 samajik vigyan social science ncert books in hindi ncert books are a popular choice among students it is also popular among teachers in india for their comprehensive and reliable content

std 7 s s ch 1 swadhyay pothi dhoran 7 samajik vigyan chapter 1 - Jul 16 2023

web jun 10 2022 std 7 social science ch 1 swadhyay pothi dhoran 7 samajik vigyan swadhyaypothi part 1 std 7 samajik vigyan chapter 1 swadhyaypothi

ncert - Feb 11 2023

web learning outcomes already developed by the ncert across classes had been taken into consideration in this exercise contents of the textbooks had been rationalised in view of the following content based on genres of literature in the textbooks and supplementary readers at different stages of school education

**amazon in ncert class 10 vigyan** - Apr 01 2022

web loktantrik rajniti 2 textbook of samajik vigyan for class 10 1073 bharat aur samkalin vishwa 2 textbook of itihast for class 10 1067 set of 2 books hindi edition 5 0 out of 5 stars 2 product bundle

**ncert solutions for class 7 social science history chapter 3 youtube** - Nov 08 2022

web kaksha 7 samajik vigyan itihast adhyay 3 for more visit to our website tiwariacademy com ncert s and get the solutions in pdf file format show more

class 7 samajik vigyan - Sep 18 2023

web class 7 samajik vigyan videos mcq samajik vigyan class 7 geography class 7 civics class 7 history class 7 class 7

**std 7 samajik vigyan chapter 1 youtube** - Jan 10 2023

web std 7 samajik vigyan chapter 1 amd education 185k subscribers subscribe 141 share save 9 9k views 3 years ago

meeducation mathseducation educationmaths std

**ncert solutions for class 7 social science civics chapter 4 youtube** - Mar 12 2023

web sep 18 2021 subscribe 11k views 1 year ago ncert solutions for class 7 social science civics in hindi medium ncert

solutions for class 7 social science political science chapter 4 ladke aur ladkiyon ke

**ncert** - Aug 17 2023

web ncert sri aurobindo marg new delhi 110016 dceta ncert nic in 91 8800440559

Honda 2315 V Twin Manual: Bestsellers in 2023 The year 2023 has witnessed a noteworthy surge in literary brilliance, with numerous captivating novels captivating the hearts of readers worldwide. Lets delve into the realm of top-selling books, exploring the captivating narratives that have charmed audiences this year. The Must-Read : Colleen Hoover's "It Ends with Us" This touching tale of love, loss, and resilience has captivated readers with its raw and emotional exploration of domestic abuse. Hoover masterfully weaves a story of hope and healing, reminding us that even in the darkest of times, the human spirit can prevail. Honda 2315 V Twin Manual : Taylor Jenkins Reids "The Seven Husbands of Evelyn Hugo" This captivating historical fiction novel unravels the life of Evelyn Hugo, a Hollywood icon who defies expectations and societal norms to pursue her dreams. Reids absorbing storytelling and compelling characters transport readers to a bygone era, immersing them in a world of glamour, ambition, and self-discovery. Discover the Magic : Delia Owens "Where the Crawdads Sing" This evocative coming-of-age story follows Kya Clark, a young woman who grows up alone in the marshes of North Carolina. Owens crafts a tale of resilience, survival, and the transformative power of nature, entrancing readers with its evocative prose and mesmerizing setting. These popular novels represent just a fraction of the literary treasures that have emerged in 2023. Whether you seek tales of romance, adventure, or personal growth, the world of literature offers an abundance of captivating stories waiting to be discovered. The novel begins with Richard Papen, a bright but troubled young man, arriving at Hampden College. Richard is immediately drawn to the group of students who call themselves the Classics Club. The club is led by Henry Winter, a brilliant and charismatic young man. Henry is obsessed with Greek mythology and philosophy, and he quickly draws Richard into his world. The other members of the Classics Club are equally as fascinating. Bunny Corcoran is a wealthy and spoiled young man who is always looking for a good time. Charles Tavis is a quiet and reserved young man who is deeply in love with Henry. Camilla Macaulay is a beautiful and intelligent young woman who is drawn to the power and danger of the Classics Club. The students are all deeply in love with Morrow, and they are willing to do anything to please him. Morrow is a complex and mysterious figure, and he seems to be manipulating the students for his own purposes. As the students become more involved with Morrow, they begin to commit increasingly dangerous acts. The Secret History is an exceptional and gripping novel that will keep you wondering until the very end. The novel is a cautionary tale about the dangers of obsession and the power of evil.

[https://offsite.creighton.edu/files/virtual-library/Documents/how\\_to\\_build\\_wooden\\_boats.pdf](https://offsite.creighton.edu/files/virtual-library/Documents/how_to_build_wooden_boats.pdf)

[https://offsite.creighton.edu/files/virtual-library/Documents/how\\_much\\_is\\_an\\_mrap.pdf](https://offsite.creighton.edu/files/virtual-library/Documents/how_much_is_an_mrap.pdf)

## **Table of Contents Honda 2315 V Twin Manual**

1. Understanding the eBook Honda 2315 V Twin Manual
  - The Rise of Digital Reading Honda 2315 V Twin Manual
  - Advantages of eBooks Over Traditional Books
2. Identifying Honda 2315 V Twin Manual
  - Exploring Different Genres
  - Considering Fiction vs. Non-Fiction
  - Determining Your Reading Goals
3. Choosing the Right eBook Platform
  - Popular eBook Platforms
  - Features to Look for in an Honda 2315 V Twin Manual
  - User-Friendly Interface
4. Exploring eBook Recommendations from Honda 2315 V Twin Manual
  - Personalized Recommendations
  - Honda 2315 V Twin Manual User Reviews and Ratings
  - Honda 2315 V Twin Manual and Bestseller Lists
5. Accessing Honda 2315 V Twin Manual Free and Paid eBooks
  - Honda 2315 V Twin Manual Public Domain eBooks
  - Honda 2315 V Twin Manual eBook Subscription Services
  - Honda 2315 V Twin Manual Budget-Friendly Options
6. Navigating Honda 2315 V Twin Manual eBook Formats
  - ePub, PDF, MOBI, and More
  - Honda 2315 V Twin Manual Compatibility with Devices
  - Honda 2315 V Twin Manual Enhanced eBook Features
7. Enhancing Your Reading Experience

- Adjustable Fonts and Text Sizes of Honda 2315 V Twin Manual
- Highlighting and Note-Taking Honda 2315 V Twin Manual
- Interactive Elements Honda 2315 V Twin Manual
- 8. Staying Engaged with Honda 2315 V Twin Manual
  - Joining Online Reading Communities
  - Participating in Virtual Book Clubs
  - Following Authors and Publishers Honda 2315 V Twin Manual
- 9. Balancing eBooks and Physical Books Honda 2315 V Twin Manual
  - Benefits of a Digital Library
  - Creating a Diverse Reading Collection Honda 2315 V Twin Manual
- 10. Overcoming Reading Challenges
  - Dealing with Digital Eye Strain
  - Minimizing Distractions
  - Managing Screen Time
- 11. Cultivating a Reading Routine Honda 2315 V Twin Manual
  - Setting Reading Goals Honda 2315 V Twin Manual
  - Carving Out Dedicated Reading Time
- 12. Sourcing Reliable Information of Honda 2315 V Twin Manual
  - Fact-Checking eBook Content of Honda 2315 V Twin Manual
  - Distinguishing Credible Sources
- 13. Promoting Lifelong Learning
  - Utilizing eBooks for Skill Development
  - Exploring Educational eBooks
- 14. Embracing eBook Trends
  - Integration of Multimedia Elements
  - Interactive and Gamified eBooks

## **Honda 2315 V Twin Manual Introduction**

In this digital age, the convenience of accessing information at our fingertips has become a necessity. Whether its research papers, eBooks, or user manuals, PDF files have become the preferred format for sharing and reading documents. However,

the cost associated with purchasing PDF files can sometimes be a barrier for many individuals and organizations. Thankfully, there are numerous websites and platforms that allow users to download free PDF files legally. In this article, we will explore some of the best platforms to download free PDFs. One of the most popular platforms to download free PDF files is Project Gutenberg. This online library offers over 60,000 free eBooks that are in the public domain. From classic literature to historical documents, Project Gutenberg provides a wide range of PDF files that can be downloaded and enjoyed on various devices. The website is user-friendly and allows users to search for specific titles or browse through different categories. Another reliable platform for downloading Honda 2315 V Twin Manual free PDF files is Open Library. With its vast collection of over 1 million eBooks, Open Library has something for every reader. The website offers a seamless experience by providing options to borrow or download PDF files. Users simply need to create a free account to access this treasure trove of knowledge. Open Library also allows users to contribute by uploading and sharing their own PDF files, making it a collaborative platform for book enthusiasts. For those interested in academic resources, there are websites dedicated to providing free PDFs of research papers and scientific articles. One such website is Academia.edu, which allows researchers and scholars to share their work with a global audience. Users can download PDF files of research papers, theses, and dissertations covering a wide range of subjects. Academia.edu also provides a platform for discussions and networking within the academic community. When it comes to downloading Honda 2315 V Twin Manual free PDF files of magazines, brochures, and catalogs, Issuu is a popular choice. This digital publishing platform hosts a vast collection of publications from around the world. Users can search for specific titles or explore various categories and genres. Issuu offers a seamless reading experience with its user-friendly interface and allows users to download PDF files for offline reading. Apart from dedicated platforms, search engines also play a crucial role in finding free PDF files. Google, for instance, has an advanced search feature that allows users to filter results by file type. By specifying the file type as "PDF," users can find websites that offer free PDF downloads on a specific topic. While downloading Honda 2315 V Twin Manual free PDF files is convenient, it's important to note that copyright laws must be respected. Always ensure that the PDF files you download are legally available for free. Many authors and publishers voluntarily provide free PDF versions of their work, but it's essential to be cautious and verify the authenticity of the source before downloading Honda 2315 V Twin Manual. In conclusion, the internet offers numerous platforms and websites that allow users to download free PDF files legally. Whether it's classic literature, research papers, or magazines, there is something for everyone. The platforms mentioned in this article, such as Project Gutenberg, Open Library, Academia.edu, and Issuu, provide access to a vast collection of PDF files. However, users should always be cautious and verify the legality of the source before downloading Honda 2315 V Twin Manual any PDF files. With these platforms, the world of PDF downloads is just a click away.



## FAQs About Honda 2315 V Twin Manual Books

**What is a Honda 2315 V Twin Manual PDF?** A PDF (Portable Document Format) is a file format developed by Adobe that preserves the layout and formatting of a document, regardless of the software, hardware, or operating system used to view or print it. **How do I create a Honda 2315 V Twin Manual PDF?** There are several ways to create a PDF: Use software like Adobe Acrobat, Microsoft Word, or Google Docs, which often have built-in PDF creation tools. Print to PDF: Many applications and operating systems have a "Print to PDF" option that allows you to save a document as a PDF file instead of printing it on paper. Online converters: There are various online tools that can convert different file types to PDF. **How do I edit a Honda 2315 V Twin Manual PDF?** Editing a PDF can be done with software like Adobe Acrobat, which allows direct editing of text, images, and other elements within the PDF. Some free tools, like PDFescape or Smallpdf, also offer basic editing capabilities. **How do I convert a Honda 2315 V Twin Manual PDF to another file format?** There are multiple ways to convert a PDF to another format: Use online converters like Smallpdf, Zamzar, or Adobe Acrobats export feature to convert PDFs to formats like Word, Excel, JPEG, etc. Software like Adobe Acrobat, Microsoft Word, or other PDF editors may have options to export or save PDFs in different formats. **How do I password-protect a Honda 2315 V Twin Manual PDF?** Most PDF editing software allows you to add password protection. In Adobe Acrobat, for instance, you can go to "File" -> "Properties" -> "Security" to set a password to restrict access or editing capabilities. Are there any free alternatives to Adobe Acrobat for working with PDFs? Yes, there are many free alternatives for working with PDFs, such as: LibreOffice: Offers PDF editing features. PDFsam: Allows splitting, merging, and editing PDFs. Foxit Reader: Provides basic PDF viewing and editing capabilities. How do I compress a PDF file? You can use online tools like Smallpdf, ILovePDF, or desktop software like Adobe Acrobat to compress PDF files without significant quality loss. Compression reduces the file size, making it easier to share and download. Can I fill out forms in a PDF file? Yes, most PDF viewers/editors like Adobe Acrobat, Preview (on Mac), or various online tools allow you to fill out forms in PDF files by selecting text fields and entering information. Are there any restrictions when working with PDFs? Some PDFs might have restrictions set by their creator, such as password protection, editing restrictions, or print restrictions. Breaking these restrictions might require specific software or tools, which may or may not be legal depending on the circumstances and local laws.

## Find Honda 2315 V Twin Manual :

[how to build wooden boats](#)

[how much is an mrap](#)

[hospice nurses experiences with angels](#)

[how does the lymphatic system interact with the circulatory system](#)

*[how to be fearless under pressure](#)*

[house electrical drawing symbols](#)

*[how old is poe dameron](#)*

[home owner manual](#)

*[how many questions is the packrat](#)*

[how immune system works pdf](#)

~~[how many questions on the new cissp exam](#)~~

**[how the world really works by vaclav smil pdf](#)**

*[how do you open your chakras for beginners](#)*

~~[how old is jiji from st math](#)~~

[how long are pimsleur lessons](#)

**Honda 2315 V Twin Manual :**