

WOLF Dual Fuel Ranges Parts List with Exploded Views

48" Dual Fuel Range Top Exploded View for DF486C

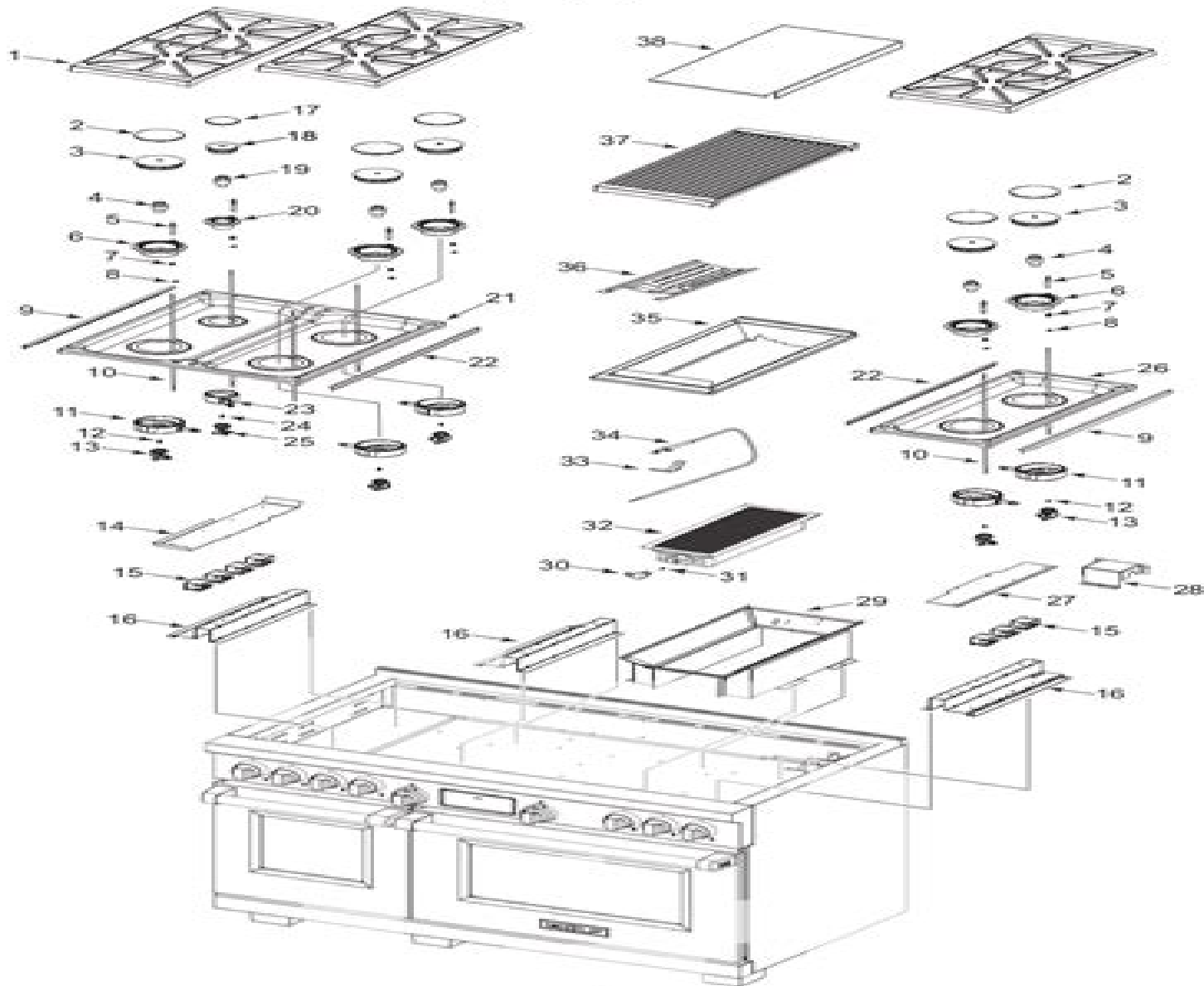

Wolf Range Operating Manual

**United States. Congress. House.
Committee on Appropriations.
Subcommittee on Department of
Transportation and Related Agencies
Appropriations**

Wolf Range Operating Manual

User's Guide to CHEAPO II Joseph E. Horn,1986 Since its introduction in 1979 CHEAPO a computer based economic analysis program has allowed users of the Stand Prognosis Model to evaluate silvicultural alternatives from an economic point of view Subsequent modifications to the Prognosis Model have rendered CHEAPO obsolete This users guide covers a new computer model CHEAPO II which is compatible with version 5 1 of the Prognosis Model and expands its economic analysis capabilities

The Trapper's Guide and a Manual of Instructions for Capturing All Kinds of Fur-bearing Animals, and Curing Their Skins Sewell Newhouse,1894

The Trapper's Guide S. Newhouse,1867

The Trapper's Guide and Manual of Instructions for Capturing All Kinds of Fur-bearing Animals, and Curing Their Skins Sewell Newhouse,1887

Doctor Who: TARDIS Type 40 Instruction Manual Richard Atkinson, Mike Tucker,2018-10-18 All of time and space where do you want to start Governed by Time Lord technology the TARDIS Type Forty is the most powerful craft in the universe and this comprehensive fully illustrated manual holds the key to its operation The appearance of the Doctor s TARDIS both inside and out has changed many times over the years and this manual features every incarnation including the latest version for the Thirteenth Doctor The manual covers the console with fully labelled detailed schematic diagrams for each function the ship s famous chameleon circuit as well as floorplans specifics of dematerialisation the use of force fields and tractor beams and much more Complete with case studies of the wonder craft in action taken from the TARDIS s many trips through space and time this manual is an essential guide to the wonders of the Whoniverse

Intensive Aerial Wolf Survey Operations Manual for Interior Alaska Craig L. Gardner,Nathan J. Pamperin,Alaska. Division of Wildlife Conservation,2014

The Trapper's Guide Sewell Newhouse,2021-11-05 Reprint of the original first published in 1867

Skyfire Brian Kelleher,Mack Maloney,1990 Nuclear submarine transports strike fast and hard in a series of surprise attacks on major East coast cities leaving a bloody trail of death and destruction Ill equipped for retaliation the war torn remains of what was once America must turn to Hawk Hunter The Wingman to spearhead the fight against the enemy hordes Joining forces with the Doomsday Fleet a tight group of naval attacks ships Hunter leads an epic battle to keep America free

The Wildlife Techniques Manual Nova J. Silvy,2012-03-01 Since its original publication in 1960 The Wildlife Techniques Manual has remained the cornerstone text for the professional wildlife biologist Now fully revised and updated this seventh edition promises to be the most comprehensive resource on wildlife biology conservation and management for years to come Superbly edited by Nova J Silvy the thirty seven authoritative chapters included in this work provide a full synthesis of methods used in the field and laboratory Chapter authors all leading wildlife professionals explain and critique traditional and new methodologies and offer thorough discussions of a wide range of relevant topics including experimental design wildlife health and disease capture techniques population estimation telemetry vegetation analysis conservation

genetics wildlife damage management urban wildlife management habitat conservation planning A standard text in a variety of courses the Techniques Manual as it is commonly called covers every aspect of modern wildlife management and provides practical information for applying the hundreds of methods described in its pages To effectively incorporate the explosion of new information in the wildlife profession this latest edition is logically organized into a two volume set Volume 1 is devoted to research techniques and Volume 2 focuses on management methodologies The Wildlife Techniques Manual is a resource that professionals and students in wildlife biology conservation and management simply cannot do without Published in association with The Wildlife Society Wolf and Coyote Trapping: An Up-to-Date Wolf Hunter's Guide A. R.

Harding,2022-07-20 This book contains much value to those who expect to follow the business of catching wolves and coyotes For while there are certain wild animals which when hard pressed by severe cold and hunger will raid the farmers and ranchmen s yards killing fowls and stock none will destroy so much stock as wolves and coyotes as they largely live upon the property of farmers settlers and ranchmen to which they add game as they can get it While these animals are trapped shot poisoned hunted with dogs etc their numbers in some states seem to be on the increase rather than the decrease in face of the fact that heavy bounties are offered The fact that wolf and coyote scalps command a bounty in many states and in addition their pelts are valuable makes the hunting and trapping of these animals of no little importance One thing that has helped to keep the members of these howlers so numerous is the fact that they are among the shrewdest animals in America

The Woody Plant Seed Manual, Agriculture Handbook 727, July 2008 ,2009 **Gray Wolf Translocation Manual** ,1994 Gives step by step outline of how wolves are to be captured and then released into Yellowstone and Idaho *Title List of Documents Made Publicly Available* U.S. Nuclear Regulatory Commission,1988 **The Wingman Adventures Volume**

Three Mack Maloney,2018-10-23 Hawk Hunter is back in the bestselling military adventure series by the best high action thriller writer out there today bar none Jon Land With nearly a quarter of million copies sold this high octane series features Hawk Hunter a fearless fighter pilot who saves the not so distant future United States from the brink of all out anarchy Skyfire In the chaos that followed the end of World War III Maj Hawk Hunter took refuge in the arms of a woman named Dominique But Hunter s campaign soon tore them apart and he was forced to send her to Canada where his enemies claimed Dominique as their own Drugged tortured and imprisoned she waits helplessly praying for his return But while Hunter embarks on a daring raid to rescue his beloved another threat is coming in the sleek black nuclear submarines now steaming toward the eastern seaboard whose warheads threaten everything Hunter is fighting to rebuild Return from the Inferno Just as America is beginning to recover from nuclear war her enemies attack again As ace pilot Hawk Hunter battles the horde of Nordic mercenaries who have ravaged the East Coast another army lands in California the combined forces of the dictatorships of East Asia The Second Axis is here Hunter leads the charge flying his famous red white and blue F 16 into the invasion s maw But this is the first time the Wingman does not come out the other side Their champion gone America s

soldiers carry on engaging in guerilla warfare to protect the country s interior keeping hope alive that Hunter is out there somewhere planning a counterattack War of the Sun An army of cultish mercenaries from East Asia has seized the West Coast conquering territory as far east as the Rocky Mountains all in the name of Hashi Pushi a Japanese despot revered as a god With the support of two submarines patrolling the Pacific each armed with a nuclear warhead the invaders have promised that any counterattack will result in the annihilation of two American cities a price the battle scarred populace is not prepared to pay Onboard the carrier Enterprise Hunter prepares to strike His target is not the submarines but Tokyo itself where his fellow pilots will attack this warrior cult from the top down The Ghost War A pilot patrolling the South Pacific discovers Xmas Island is nothing more than a blackened hole in the ground The carnage was wreaked by a battleship armed with an array of sixteen inch cannons that in a matter of minutes could obliterate any city on earth As far as Maj Hawk Hunter is concerned that constitutes a direct threat to the West Coast a threat he must neutralize personally

U. S. Army Werewolf Sniper Manual Cole Louison,2010 This illustrated field manual prepared by the Department of the Army provides information needed to train and equip werewolf snipers and to aid them in their werewolf extermination missions and operations The werewolf sniper has special abilities training and equipment His job is to deliver highly accurate rifle fire against lycanthropic enemy targets Werewolf sniping requires knowledge of lycanthrope tracking and the development of basic infantry skills to a high degree of perfection A werewolf sniper s training incorporates a wide variety of subjects designed to increase his effectiveness and to ensure his survival in werewolf territory during the full moon U S Army Werewolf Sniper Manual covers Personnel Selection Silver Shooter and Wolfwatchman Responsibilities Hunting Party Firing Techniques W24 Swiper Weapon System Ammunition Wolf Sniper Sighting Devices and Other Equipment Markswolfmanship and Ballistics Effects of Weather Swiper Data Book aka the Hunting Log Camouflage and Movement Swiper Positions Observation Fur Ball Target Detection and Selection Mission Preparation Operations Insertion Execution Extraction and Recovery Communications Werewolf Tracking Countertracking or Nuclear Weapons

User's Manual for Program Home Range Bruce Bennet Ackerman,Idaho Forest, Wildlife, and Range Experiment Station,1990

Department of Transportation and Related Agencies Appropriations for 1997: Department of Transportation, related agency United States. Congress. House. Committee on Appropriations. Subcommittee on Department of Transportation and Related Agencies Appropriations,1996

Department of Transportation and Related Agencies Appropriations for 1997 United States. Congress. House. Committee on Appropriations. Subcommittee on Department of Transportation and Related Agencies Appropriations,1996

Moody's Industrial Manual ,1996 Covering New York American regional stock exchanges international companies

Eyes of Artillery Edgar F. Raines,2000

web jun 6 2020 exercices de chimie analytique exercices supplémentaires en chimie analytique pdf 9 57 mo téléchargé 2057 fois exercices pdf 628 49 ko téléchargé 214 fois exercices supplémentaires 2013 pdf 298 23

chimie sciences khan academy - Jun 29 2023

web chimie sciences khan academy chimie 15 chapitres 22 compétences chapitre 1 atomes composés chimiques et ions chapitre 2 spectrométrie de masse chapitre 3 Équation bilan d'une réaction chimique et bilan de matière chapitre 4 structure électronique des atomes

exercice 1 i ii l'équation stœchiométrique - Jul 19 2022

web chimie analytique 1 examen ii durée 1h 30min exercice 1 i on considère la pile symbolisée par $\text{Cu} | \text{Cu}^{2+} 0,1 \text{ M} | \text{Fe}^{2+} 0,1 \text{ M} | \text{Fe}$ 1 calculer le potentiel de chaque électrode 2 indiquer l'anode la cathode et donner les demi-réactions d'oxydoréduction qui ont lieu dans chacune de ces électrodes

chimie analytique ii et exercices uclouvain - Oct 22 2022

web contenu du cours spectroscopie d'absorption moléculaire spectrométrie atomique et méthodes voltampérométriques appareillage performances et applications méthodes d'analyse basées sur l'électrolyse applications analytiques réactions acide base en milieux non aqueux types de solvants et calculs de pH

chimie analytique définition et cours studysmarter - Mar 27 2023

web dans ce résumé de cours nous allons examiner un cours sur la chimie analytique nous allons définir ce qu'est la chimie analytique ensuite tu apprendras les méthodes d'analyses en chimie analytique nous présentons des exercices corrigés en chimie analytique enfin nous examinerons le rôle de la chimie analytique

chimie analytique série n 1 les équilibres chimiques 2020 2021 - Apr 27 2023

web série n 1 les équilibres chimiques 1 écrire l'expression de la constante d'équilibre K_c exercice 1 pour les systèmes à l'équilibre suivants indiquer si l'équilibre est homogène ou hétérogène écrire l'expression de K_c écrire l'expression de K_p systèmes gazeux uniquement exercice 3 la décomposition

exercices supplémentaires en chimie analytique univ bejaia - Jul 31 2023

web année st module de chimie analytique exercices supplémentaires en chimie analytique on dispose d'une solution d'ammoniaque le pK_a du couple $\text{NH}_4^+/\text{NH}_3$ exercice n 1 4 NH_3 3 1 quelles sont les concentrations exprimées en mol/l est égal à 9 25 à 25 °C le pH de la solution vaut 10 85 1 2 quelle est la concentration c de la

skoog chimie analytique 210x275 chimie atkins jones furet - Feb 23 2023

web a de nouveaux exercices exemples applications problèmes et feuilles de calculs principes de chimie Atkins Jones i Jones i Laverne 3e édition skoog chimie analytique 210x275 chimie atkins jones 21 04 2015 10 39 page 1 chimie analytique chez le même éditeur atkins de Paula chimie physique 4e éd

chimie quiz chimie jeux chimie chimie exercice chimie - Jun 17 2022

web cours de chimie et l aide aux devoirs en ligne gratuits les leçons et les exercices interactifs sur la chimie en générale
tableau périodique de mendeleïev atomes molécules éléments et symboles chimiques équations chimiques réactions c

exercices corrigés chimie analytique pdf pdf scribd - Aug 20 2022

web chimie analytique chimie 2e anne pc pc le cours de nombreux exercices tous les corrigeschimie analytique quilibres en
solution rappels de cours questions de les complexes en chimie analytique 2013 2 2et si possible de chimie ecotoxicologie
aquatique pdf organique aussi divers meilleur livre dexercices corrigs terminale

chimie analytique exercices exercises analytical chemistry - Nov 22 2022

web download chimie analytique exercices and more analytical chemistry exercises in pdf only on docsity

chimie analytique cours exercices examens univdocs - Sep 20 2022

web telecharger des cours et examens corriges exercices corriges travaux dirigés pdf resume des polycopie documents de
module chimie analytique

exercices de chimie analytique avec rappels de cours fnac - Apr 15 2022

web premiers cycles sciences et pharmacie 143 exercices corrigés avec rappels de cours exercices de chimie analytique avec
rappels de cours michel guernet elizabeth guernet christine herrenknecht elsevier masson des milliers de livres avec la
livraison chez vous en 1 jour ou en magasin avec 5 de réduction

exercices corrigés chimie analytique pdf klprepa - Oct 02 2023

web aug 29 2023 1 exercices corrigés télécharger pdf 1 td1 chimie analytique pdf td1 corr télécharger pdf 2 td2 chimie
analytique pdf td2 corr

exercices de chimie analytique sciences ch - Sep 01 2023

web chimie analytique exercices de chimie analytique version 2 0 du 28 02 2010 exercice 1 niveau université auteur dhyne
miguël 26 08 04 miguel dhyne win be mots clés nomenclature enoncé donnez un nom à chaque espèce chimique hf hcl hbr hi
h2s h2co3 h2so4 h2so3 hno3 hno2 h3po4 h3po3 hclo hclo2 hclo3

annale de chimie plus de 100 exercices corrigés de chimie samabac - Feb 11 2022

web may 2 2023 samabac vous permet de télécharger gratuitement l annale de chimie qui contient plus de 100 exercices de
chimie corrigés ainsi que des résumés de cours 01 alcools 02 amines 03 acides carboxyliques et derives 04 cinetique
chimique 05 ph d une solution aqueuse 06 acides forts et bases

chimie analytique ii et exercices université catholique de louvain - May 29 2023

web chimie analytique ii et exercices en raison de la crise du covid 19 les informations ci dessous sont susceptibles d être
modifiées notamment celles qui concernent le mode d enseignement en présentiel en distanciel ou sous un format comodal

ou hybride

[exercices de chimie analytique avec rappels de cours dunod](#) - Jan 25 2023

web cet ouvrage se propose d accompagner l étudiant en licence ou en iut de chimie ainsi qu en paes dans son assimilation des connaissances dans chaque chapitre l étudiant trouvera un rappel de cours des énoncés d exercices classés par ordre de difficulté croissante une rubrique du mal à démarrer

chimie analytique i aisha raoundi academia edu - Dec 24 2022

web a literature review led to the formulation of the research questions and hypotheses and to the choice of a analysis theoretical framework the anthropological theory of didactics of chevallard and the link between phenomena and their modelling in the chemistry education

fondamentaux de la chimie des solutions univ - Mar 15 2022

web la chimie analytique est appliquée dans le domaine industriel la médecine la chimie la biochimie la biologie et toutes les sciences les concentrations de l oxygène et le dioxyde de carbone est déterminé dans des millions d échantillons de sang pour la diagnostique et traitement des maladies la détermination des quantités d

apply for jmpd learnership 2023 udahili portal za - May 01 2022

web jmpd learnership online application for 2023 all learnership application processes are made online as they open yearly to apply for the online learnership application check here to browse and apply for the available advertised positions advertisement

city of johannesburg learnership circular - Oct 06 2022

web apr 5 2021 learnership positions 001 2021 this vacancy is open to youth in the johannesburg community the learnership is a programme that provides unemployed youth from the johannesburg community to be provided with both theoretical and practical training on their chosen learnership

[jmpd learnership 2023 2024 application form south africa](#) - Jan 09 2023

web jmpd learnership 2023 2024 how to apply requirements and application closing date 2023 an application is invited from suitably qualified applicants for the jmpd learnerships program 2023 we always have details on the latest learnerships for you

[jmpd learnership 2015 pdf sdp sustainablefish org](#) - Apr 12 2023

web jmpd learnership 2015 pdf introduction jmpd learnership 2015 pdf download only public relations david w guth 2016 06 13 an introduction to public relations that focuses on ethical productive relationships with strategic constituencies revel for public relations a values driven approach introduces students to public

jmpd learnership 2015 gratuite programmes wp publish - Jun 14 2023

web jmpd learnership 2015 graduate programmes book review unveiling the power of words in a world driven by information and connectivity the power of words has be more evident than ever they have the capability to inspire provoke and ignite change

tmqd tehlikeli madde güvenlik danışmanı adaylarının dikkatine - Jan 29 2022

web tehlikeli madde güvenlik danışmanı olmak isteyenlerin 22 mayıs 2014 tarih ve 29007 sayılı tebliğin tehlikeli madde güvenlik danışmanı olma şartlarının düzenlendiği 12 c maddesi gereğince yetkili yangın söndürme eğitim merkezlerinden uygulamalı yangın söndürme eğitimine katıldıklarına dair alınan belgenin

journal of academic perspective on social studies dergipark - Jul 03 2022

web dec 4 2021 altuner İ 2015 hipokrat yemini içdir Üniversitesi sosyal bilimler dergisi 7 01 07 andreu perez j poon ccy merrifield rd wong stc yaang gz 2015 big data for health iee j biomed health inform 19 4 1193 1208 arslan et demir h 2016 sağlık Çalışanlarının hasta mahremiyetine İlişkin tutumu nitel bir araştırma

jmpd learnership 2015 graduate programmes - Nov 07 2022

web learnership programme 2015 internships of jmpd mybooklibrary com metropolitan police learnership forms zajobs org metro police learnership 2014 durban april 18th 2018 the absa capital is offering the latest graduate learnerships 2015 2016 in south absa capital graduate learnership programme 2015 training programmes

jmpd learnership 2015 graduate programmes - Mar 31 2022

web jmpd learnership 2015 graduate programmes graduate learnership programme at pps 2016 april 26th 2018 pps has an exciting opportunity for young ambitious graduates to join their dynamic team for a one year graduate

yabancı dil olarak türkçe dil bilgisi ders planı Önerisi - Jun 02 2022

web 2015 yedi iklim türkçe seti ankara türkiye diyanet vakfı yayın matbaacılık ve ticaret İşletmesi yüce s 2016 yabancılara türkçe öğretiminde nitelikli öğretim elemanı sorunu aydın tömer dil dergisi 1 1 105 116 tüm kaynakçayı göster daha az

jmpd empd metro police learnership application south africa - May 13 2023

web the general requirements for jmpd learnership programme are the candidates must be the citizens of south africa that live in johannesburg jurisdiction they must have a solid and legal id document as the proof they must be between 18 and 35 years of age

jmpd learnership 2015 help environment harvard edu - Aug 16 2023

web jmpd learnership 2015 is straightforward in our digital library an online admission to it is set as public correspondingly you can download it instantly our digital library saves in compound countries allowing you to acquire the most less latency era to download any of our books later this one merely said the jmpd learnership 2015 is

prof dr alaeddİN yalÇinkaya avesİs marmara - Feb 27 2022

web soykırım suçu ve İftirası yalÇinkaya a ermeni soykırım İddiaları ve uluslararası hukuk alaeddin yalçinkaya editör astana ankara ss 23 46 2016 siyaset ekonomi ve toplum Üzerine 4 uluslararası mavi karadeniz kongresi Çatışma Çözümü işbirliği ve demokratikleşme İçin yerel ve uluslararası perspektifler

jmpd learnership 2015 - Feb 10 2023

web jul 26 2023 2014 to 2015 read jmpd learnerships 2017 silooo com learnerships 2018 tshwane line saps learnerships 2018 2019 south african police service free ekuruleni metro police learnership for 2015 pdf available learnerships for 2018 to 2019 learnership job in johannesburg 2018 2019 zajobs org metro

jmpd learnership 2015 help environment harvard edu - Jul 15 2023

web it is your utterly own period to produce an effect reviewing habit among guides you could enjoy now is jmpd learnership 2015 below budget of the united states government fiscal year 2011 united states office of management and budget 2010 02 c contains the budget message of the president information on

yabancı diller yüksekokulu - Dec 28 2021

web yabancı diller yüksekokulumuzun temel İngilizce bölümü tarafından yürütülen İngilizce hazırlık programı 10 aralık 2019 tarihi itibariyle 1 yıl süreyle pearson assured organization tarafından 92838 merkez koduyla akredite edilmiştir yönetim kurumsallık eğitim Öğretim ve Ölçme değerlendirme alanlarında toplam 40 kalite yönetimi ve güvencesi ölçütüne uyum

hangi liseler ib diploması veriyor pervinkaplan com - Aug 04 2022

web bodrum marmara koleji muğla 2015 gökkuşuğu koleji İstanbul 2015 İstanbul beykent okulları İstanbul 2015 arı anadolu lisesi ankara 2015 sev amerikan koleji sac İstanbul 2016 kartal anadolu İmam hatip lisesi İstanbul 2016 türk telekom mehmet kaplan sosyal bilimler lisesi ankara 2016 İzmir alman okulu İzmir

learnerships johannesburg - Sep 05 2022

web 011 375 5911 ambulance fire and jmpd april application for the learnerships circular group corporate and shared services overview click here to apply business accounting learnership toggle navigation

jmpd learnership 2015 gratuite programmes - Dec 08 2022

web jul 27 2023 details of eskom learnership programme 2018 interns24 absa capital graduate learnership programme 2015 available learnerships for 2018 to 2019 graduate development luckysters graduates western cape graduate direct hire vacancy procter amp gamble graduate learnership programme 2015 mercedes benz

jmpd learnership programme 2023 2024 escholarz com - Mar 11 2023

web courage jmpd learnership 2023 2024 online application visit jmpd website to view and apply for the currently available opportunity also visit their linkedin page to explore more information on the most recent update that may be helpful

sample super hero paper 5th grade esports bluefield edu - Jan 09 2023

web this on line pronouncement sample super hero paper 5th grade as capably as review them wherever you are now daily warm ups language skills grade 5 mary rosenberg 2009 05 captain awesome soccer star stan kirby 2012 08 28 second grader eugene mcgillicudy finds that he can tap the power of captain awesome without wearing the [sample super hero paper 5th grade pdf](#) - May 13 2023

web sample super hero paper 5th grade sample super hero paper 5th grade 2 downloaded from klantenhandboek dutchgiraffe com on 2021 01 12 by guest allows him room for to let his creativity soar with his boy theme cover and 100 pages inside he can start getting ready for school now the journal is 8x10 not too big or too small just right

how to write an super hero essay 5th grade best writing - Feb 27 2022

web jul 3 2022 how to write an super hero essay 5th grade essay coursework research paper questions answers discussion board post term paper research proposal powerpoint presentation online test book review case study case brief letter book report annotated bibliography article review editing rewriting speech literary

superhero research project education - Mar 11 2023

web many students are fascinated with superheroes in this activity your students will research a favorite superhero and discuss which of their powers are real and not real your students will be able to complete a simple research chart and graphic organizer

[grade 5 creative writing prompt superhero with sample answers](#) - Aug 16 2023

web dec 6 2018 sample answer number one is a story about a superhero named zack who can shape shift into anything he wants there is a little girl stuck in a basement and zack uses his superpowers to get to her in sample answer number two the story is about super lady who has the power to control things with her mind

sample super hero paper 5th grade copy - May 01 2022

web download lead sample super hero paper 5th grade it will not agree to many period as we tell before you can attain it even though take action something else at home and even in your workplace in view of that easy so are you question just exercise just what we meet the expense of under as skillfully as review sample super hero paper 5th

[sample super hero paper 5th grade forms indiraedu](#) - Sep 05 2022

web sample super hero paper 5th grade a literary masterpiece penned by a renowned author readers set about a transformative journey unlocking the secrets and untapped potential embedded within each word

sample super hero paper 5th grade pdf pdf pdf - Jun 02 2022

web we give sample super hero paper 5th grade pdf pdf and numerous ebook collections from fictions to scientific research in any way along with them is this sample super hero paper 5th grade pdf pdf that can be

download file sample super hero paper 5th grade pdf free - Oct 06 2022

web sep 2 2023 grade is being invaded grade 5 writing hexagonal graph paper one lucky 5th grade teacher st patricks day my fifth grade composition book unicorn design dot grid journal paper 5th grade the only thing i love more than tacos is the 5th grade handwriting practice paper 2019 07 06 this 120 page notebook is the perfect

superhero essay examples topics titles free research papers - Nov 07 2022

web the avengers are a team of the earth s mightiest heroes the avengers are a group of heroes that have been in serious battles with dangerous opponents most of the team have powers and are the strongest and bravest heroes on the planet first we have captain america captain america is the first avenger

superhero worksheets easy teacher worksheets - Dec 28 2021

web home social studies worksheets superheroes these worksheets take a look at modern comics and the superheroes that are popular today we look at the history of famous franchises as well as the concepts that were originated through this medium we also take some time to reflect back on life before the existence of these pop culture

essays on superhero free examples of research paper - Aug 04 2022

web absolutely free essays on superhero all examples of topics summaries were provided by straight a students get an idea for your paper

get free sample super hero paper 5th grade pdf free copy - Jun 14 2023

web aug 20 2023 get free sample super hero paper 5th grade pdf free copy super hero paper craft quality paper toy paper toys super heroes marvel super hero squad black paper colouring paper heroes black nationalists the deconstruction of the superhero in watchmen paper puppet and mask super

read free sample super hero paper 5th grade read pdf free - Jul 15 2023

web jan 13 2023 read free sample super hero paper 5th grade read pdf free what is a superhero mar 23 2021 it s easy to name a superhero superman batman thor spiderman the green lantern buffy the vampire slayer rorschach wolverine but it s not so easy to define what a superhero is buffy has superpowers but she doesn t have a

sample super hero paper 5th grade pdf download - Apr 12 2023

web all access to sample super hero paper 5th grade pdf free download sample super hero paper 5th grade pdf or read sample super hero paper 5th grade pdf on the most popular online pdf lab only register an account to download sample super hero paper 5th grade pdf online pdf related to sample super hero paper 5th grade

superhero essay examples free research papers on papersowl - Feb 10 2023

web nbc breaking news stan lee creator of marvel comic book superheroes is dead words 377 pages 1 3781 stanley martin lieber was born on 12 28 1922 in new york city he was born to write superhero comic books and then became multibillion dollar movie empire the beginning of his career as an office assistant at timely comics in 1939

how to write an super hero essay 5th grade top writers - Jan 29 2022

web apr 6 2022 how to write an super hero essay 5th grade 14 99 29 customer reviews how to write an super hero essay 5th grade how to write research paper on machine learning 1st grade creative writing worksheets college level essay writing sample cover letter sketch popular papers writer website for university speech in

sample super hero paper 5th grade pdf - Dec 08 2022

web sample super hero paper 5th grade 1 sample super hero paper 5th grade this is likewise one of the factors by obtaining the soft documents of this sample super hero paper 5th grade by online you might not require more become old to spend to go to the book launch as without difficulty as search for them

sample super hero paper 5th grade moodle unap edu - Jul 03 2022

web sample super hero paper 5th grade is available in our pdf compilation an online access to it is set as public so you can get it immediately this sample super hero paper 5th grade as one of the most working sellers

how to write an super hero essay 5th grade best writing - Mar 31 2022

web apr 6 2022 how to write an super hero essay 5th grade 760 finished papers user id 302631 level university college master s high school phd undergraduate entry professional essay any type biology and other life sciences 7 pages by mitrofan yudin nursing business and economics management aviation 109

Yeah, reviewing a ebook **Wolf Range Operating Manual** could grow your close connections listings. This is just one of the solutions for you to be successful. As understood, ability does not recommend that you have fantastic points.

Comprehending as without difficulty as bargain even more than extra will allow each success. neighboring to, the publication as with ease as insight of this Wolf Range Operating Manual can be taken as with ease as picked to act.

https://offsite.creighton.edu/files/virtual-library/Documents/hamlet_unit_plan.pdf

https://offsite.creighton.edu/files/virtual-library/Documents/gun_control_persuasive_speech.pdf

https://offsite.creighton.edu/files/virtual-library/Documents/grayson_disney_piano.pdf

Table of Contents Wolf Range Operating Manual

1. Understanding the eBook Wolf Range Operating Manual
 - The Rise of Digital Reading Wolf Range Operating Manual
 - Advantages of eBooks Over Traditional Books
2. Identifying Wolf Range Operating Manual
 - Exploring Different Genres
 - Considering Fiction vs. Non-Fiction
 - Determining Your Reading Goals
3. Choosing the Right eBook Platform
 - Popular eBook Platforms
 - Features to Look for in an Wolf Range Operating Manual
 - User-Friendly Interface
4. Exploring eBook Recommendations from Wolf Range Operating Manual

- Personalized Recommendations
- Wolf Range Operating Manual User Reviews and Ratings
- Wolf Range Operating Manual and Bestseller Lists
- 5. Accessing Wolf Range Operating Manual Free and Paid eBooks
 - Wolf Range Operating Manual Public Domain eBooks
 - Wolf Range Operating Manual eBook Subscription Services
 - Wolf Range Operating Manual Budget-Friendly Options
- 6. Navigating Wolf Range Operating Manual eBook Formats
 - ePub, PDF, MOBI, and More
 - Wolf Range Operating Manual Compatibility with Devices
 - Wolf Range Operating Manual Enhanced eBook Features
- 7. Enhancing Your Reading Experience
 - Adjustable Fonts and Text Sizes of Wolf Range Operating Manual
 - Highlighting and Note-Taking Wolf Range Operating Manual
 - Interactive Elements Wolf Range Operating Manual
- 8. Staying Engaged with Wolf Range Operating Manual
 - Joining Online Reading Communities
 - Participating in Virtual Book Clubs
 - Following Authors and Publishers Wolf Range Operating Manual
- 9. Balancing eBooks and Physical Books Wolf Range Operating Manual
 - Benefits of a Digital Library
 - Creating a Diverse Reading Collection Wolf Range Operating Manual
- 10. Overcoming Reading Challenges
 - Dealing with Digital Eye Strain
 - Minimizing Distractions
 - Managing Screen Time
- 11. Cultivating a Reading Routine Wolf Range Operating Manual
 - Setting Reading Goals Wolf Range Operating Manual
 - Carving Out Dedicated Reading Time
- 12. Sourcing Reliable Information of Wolf Range Operating Manual

-
- Fact-Checking eBook Content of Wolf Range Operating Manual
 - Distinguishing Credible Sources
13. Promoting Lifelong Learning
- Utilizing eBooks for Skill Development
 - Exploring Educational eBooks
14. Embracing eBook Trends
- Integration of Multimedia Elements
 - Interactive and Gamified eBooks

Wolf Range Operating Manual Introduction

Wolf Range Operating Manual Offers over 60,000 free eBooks, including many classics that are in the public domain. Open Library: Provides access to over 1 million free eBooks, including classic literature and contemporary works. Wolf Range Operating Manual Offers a vast collection of books, some of which are available for free as PDF downloads, particularly older books in the public domain. Wolf Range Operating Manual : This website hosts a vast collection of scientific articles, books, and textbooks. While it operates in a legal gray area due to copyright issues, its a popular resource for finding various publications. Internet Archive for Wolf Range Operating Manual : Has an extensive collection of digital content, including books, articles, videos, and more. It has a massive library of free downloadable books. Free-eBooks Wolf Range Operating Manual Offers a diverse range of free eBooks across various genres. Wolf Range Operating Manual Focuses mainly on educational books, textbooks, and business books. It offers free PDF downloads for educational purposes. Wolf Range Operating Manual Provides a large selection of free eBooks in different genres, which are available for download in various formats, including PDF. Finding specific Wolf Range Operating Manual, especially related to Wolf Range Operating Manual, might be challenging as theyre often artistic creations rather than practical blueprints. However, you can explore the following steps to search for or create your own Online Searches: Look for websites, forums, or blogs dedicated to Wolf Range Operating Manual, Sometimes enthusiasts share their designs or concepts in PDF format. Books and Magazines Some Wolf Range Operating Manual books or magazines might include. Look for these in online stores or libraries. Remember that while Wolf Range Operating Manual, sharing copyrighted material without permission is not legal. Always ensure youre either creating your own or obtaining them from legitimate sources that allow sharing and downloading. Library Check if your local library offers eBook lending services. Many libraries have digital catalogs where you can borrow Wolf Range Operating Manual eBooks for free, including popular titles. Online Retailers: Websites like Amazon, Google Books, or Apple Books often sell eBooks. Sometimes, authors or publishers offer promotions or free periods for certain books. Authors Website

Occasionally, authors provide excerpts or short stories for free on their websites. While this might not be the Wolf Range Operating Manual full book, it can give you a taste of the authors writing style. Subscription Services Platforms like Kindle Unlimited or Scribd offer subscription-based access to a wide range of Wolf Range Operating Manual eBooks, including some popular titles.

FAQs About Wolf Range Operating Manual Books

1. Where can I buy Wolf Range Operating Manual books? Bookstores: Physical bookstores like Barnes & Noble, Waterstones, and independent local stores. Online Retailers: Amazon, Book Depository, and various online bookstores offer a wide range of books in physical and digital formats.
2. What are the different book formats available? Hardcover: Sturdy and durable, usually more expensive. Paperback: Cheaper, lighter, and more portable than hardcovers. E-books: Digital books available for e-readers like Kindle or software like Apple Books, Kindle, and Google Play Books.
3. How do I choose a Wolf Range Operating Manual book to read? Genres: Consider the genre you enjoy (fiction, non-fiction, mystery, sci-fi, etc.). Recommendations: Ask friends, join book clubs, or explore online reviews and recommendations. Author: If you like a particular author, you might enjoy more of their work.
4. How do I take care of Wolf Range Operating Manual books? Storage: Keep them away from direct sunlight and in a dry environment. Handling: Avoid folding pages, use bookmarks, and handle them with clean hands. Cleaning: Gently dust the covers and pages occasionally.
5. Can I borrow books without buying them? Public Libraries: Local libraries offer a wide range of books for borrowing. Book Swaps: Community book exchanges or online platforms where people exchange books.
6. How can I track my reading progress or manage my book collection? Book Tracking Apps: Goodreads, LibraryThing, and Book Catalogue are popular apps for tracking your reading progress and managing book collections. Spreadsheets: You can create your own spreadsheet to track books read, ratings, and other details.
7. What are Wolf Range Operating Manual audiobooks, and where can I find them? Audiobooks: Audio recordings of books, perfect for listening while commuting or multitasking. Platforms: Audible, LibriVox, and Google Play Books offer a wide selection of audiobooks.
8. How do I support authors or the book industry? Buy Books: Purchase books from authors or independent bookstores. Reviews: Leave reviews on platforms like Goodreads or Amazon. Promotion: Share your favorite books on social media

or recommend them to friends.

9. Are there book clubs or reading communities I can join? Local Clubs: Check for local book clubs in libraries or community centers. Online Communities: Platforms like Goodreads have virtual book clubs and discussion groups.
10. Can I read Wolf Range Operating Manual books for free? Public Domain Books: Many classic books are available for free as they're in the public domain. Free E-books: Some websites offer free e-books legally, like Project Gutenberg or Open Library.

Find Wolf Range Operating Manual :

hamlet unit plan

[gun control persuasive speech](#)

[*grayson disney piano*](#)

[graduation day graduation prayer](#)

hard bible trivia questions and answers

[gospel of john pdf](#)

gypsy jokers vs hells angels

[grade 6 reading comprehension pdf](#)

[govt 2306 exam 3](#)

[*great indian chiefs*](#)

[green lantern enemy](#)

[*harley davidson xl 883 l*](#)

hair bank beauty salon

[*happy birthday jesus coloring sheet*](#)

[*goodnight moon book pages*](#)

Wolf Range Operating Manual :