

# INSTALLATION INSTRUCTIONS

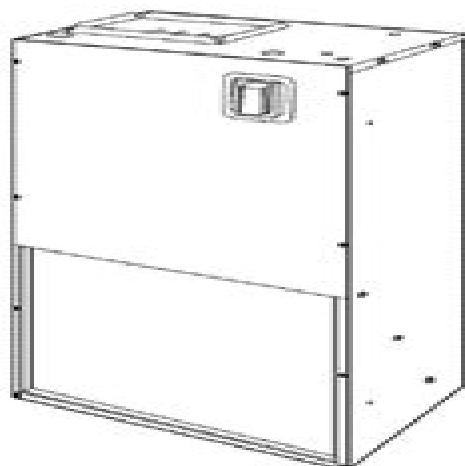

## Apartment Air Handler

Use **ONLY** factory listed electric heaters.

### Models

FWM1800A1\*  
FWM2400A1\*  
FWM3000A1\*

FWM1805A1  
FWM1807A1  
FWM1811A1

FWM2405A1  
FWM2407A1  
FWM2411A1

FWM3005A1  
FWM3007A1  
FWM3011A1

\*Requires  
AMWK001CK1  
Cooling Only Control Kit

### Contents

General Information / Installation .....	2
Installations .....	3
Ductwork Connections .....	3
Condensate Drain .....	4
Orifice Sizing & Refrigerant Lines .....	4
Field Installation of Controls .....	5
Electrical Connections .....	5
Motor Speeds .....	6
Wiring Diagram .....	7
Replacement Parts .....	8

### Safety Labeling and Signal Words

#### Danger, Warning and Caution

The signal words **DANGER**, **WARNING** and **CAUTION** are used to identify levels of hazard seriousness. The signal word **DANGER** is only used on product labels to signify an immediate hazard. The signal words **WARNING** and **CAUTION** will be used on product labels and throughout this manual and other manuals that may apply to the product.

**DANGER** - Immediate hazards which **WILL** result in severe personal injury or death.

**WARNING** - Hazards or unsafe practices which **COULD** result in severe personal injury or death.

**CAUTION** - Hazards or unsafe practices which **COULD** result in minor personal injury or product or property damage.

#### Signal Words in Manuals

The signal word **WARNING** is used throughout this manual in the following manner:

**⚠ WARNING**

The signal word **CAUTION** is used throughout this manual in the following manner:

**CAUTION**

#### Product Labeling

Signal words are used in combination with colors and/or pictures on product labels.

# **American Standard Air Handler Manual**

**Hank Rutkowski**



# American Standard Air Handler Manual

**American Standard Electro-hydronic Air Conditioners, Horizontal and Vertical** American Standard, Inc,1968  
**Air Conditioning Systems Design Manual** Harold G. Lorsch,American Society of Heating, Refrigerating and Air-Conditioning Engineers,1993 The ASHRAE 581 RP Project Team Operation and Maintenance Instructions with Illustrated Parts Breakdown ,1982 90.1 User's Manual American Society of Heating, Refrigerating and Air-Conditioning Engineers,2004 This User s Manual provides detailed instruction for the design of commercial and high rise residential buildings to ensure their compliance with ANSI ASHRAE IESNA Standard 90 1 2004 In addition this Manual encourages the user to apply the principles of effective energy conserving design when designing buildings and building systems offers information on the intent and application of Standard 90 1 illuminates the Standard through the use of abundant sample calculations and examples streamlines the process of showing compliance provides Standard forms to demonstrate compliance provides useful reference material to assist designers in efficiently completing a successful and complying design This Manual also instructs the user in the application of several tools used for compliance with Standard 90 1 the EnvStd computer program used in conjunction with the Building Envelope Trade Off compliance method the selection and application of energy simulation programs used in conjunction with the energy cost budget method of compliance This Manual is intended to be useful to numerous types of building professionals including architects and engineers who must apply the Standard to the design of their buildings plan examiners and field inspectors who must enforce the Standard in areas where it is adopted as code general and specialty contractors who must construct buildings in compliance with the standard product manufacturers state and local energy offices policy groups utilities and others **HVAC Design Manual for Hospitals and Clinics** ASHRAE (Firm),2013 Health care HVAC systems serve facilities in which the population is uniquely vulnerable and exposed to an elevated risk of health fire and safety hazard These heavily regulated high stakes facilities undergo continuous maintenance verification inspection and recertification typically operate 24 7 and are owner occupied for long life The HVAC systems in health care facilities must be carefully designed to be installed operated and maintained in coordination with specialized buildings services including emergency and normal power plumbing and medical gas systems automatic transport fire protections and a myriad of IT systems all within a limited building envelope *Air-handling Systems Ready Reference Manual* David L. Grumman,1986 **Compact Numerical Methods for Computers** John C. Nash,1990-01-01 This second edition of Compact Numerical Methods for Computers presents reliable yet compact algorithms for computational problems As in the previous edition the author considers specific mathematical problems of wide applicability develops approaches to a solution and the consequent algorithm and provides the program steps He emphasizes useful applicable methods from various scientific research fields ranging from mathematical physics to

commodity production modeling While the ubiquitous personal computer is the particular focus the methods have been implemented on computers as small as a programmable pocket calculator and as large as a highly parallel supercomputer New to the Second Edition Presents program steps as Turbo Pascal code Includes more algorithmic examples Contains an extended bibliography The accompanying software available by coupon at no charge includes not only the algorithm source codes but also driver programs example data and several utility codes to help in the software engineering of end user programs The codes are designed for rapid implementation and reliable use in a wide variety of computing environments Scientists statisticians engineers and economists who prepare modify programs for use in their work will find this resource invaluable Moreover since little previous training in numerical analysis is required the book can also be used as a supplementary text for courses on numerical methods and mathematical software *Air Force Manual* United States. Department of the Air Force,1957 **Air Conditioning Manual** Domestic Engineering Company,1937 *Operations and Maintenance Manual for Energy Management* James E. Piper,2016-06-16 A complete reference that features a wealth of proven maintenance methods that can reduce energy use in any type of building Provided are numerous forms and maintenance procedures for reducing energy use improving system performance and cutting total maintenance costs

**National Electrical Code 2011** National Fire Protection Association,2010 Safe efficient code compliant electrical installations are made simple with the latest publication of this widely popular resource Like its highly successful previous editions the National Electrical Code 2011 LOOSE LEAF combines solid thorough research based content with the tools you need to build an in depth understanding of the most important topics It provides the full text of the updated Code regulations alongside expert commentary from code specialists offering code rationale clarifications for new and updated rules and practical real world advice on how to apply the code And in a loose leaf format it s easy to customize your experience with the Code by adding job and situation specific materials New to the 2011 edition are articles including first time Article 399 on Overhead Conductors with over 600 volts first time Article 694 on Small Wind Electric Systems first time Article 840 on Premises Powered Broadband Communications Systems and more This winning combination has created a valuable reference for those in or entering careers in electrical design installation inspection and safety *Air Conditioning Manual* ,1965 *Standard 62.2 User's Manual Based on ANSI/ASHRAE Standard 62.2-2016, Ventilation and Acceptable Indoor Air Quality in Residential Buildings* American Society of Heating, Refrigerating and Air-Conditioning Engineers,2017 **THE DEFINITIVE COMPANION TO STANDARD 62.2**This companion guide provides detailed information on the requirements of Standard 62.2-2016 and includes tables illustrations and examples to aid users in providing for acceptable indoor air quality in residential systems The provisions of Standard 62.2 address mechanical and natural ventilation as well as air leakage in these buildings and this user s manual provides concrete examples on how to apply the criteria set out by the standard Standard 62.2 User s Manual does not reproduce the requirements of the standard but rather paraphrases and elaborates

upon them Intended to be used in conjunction with the standard this manual provides Information on the intent and application of Standard 62.2 Sample calculations and examples Best practices for avoiding foul odors and irritating contaminants Guidance for whole building and local exhaust ventilation Valuable information on air moving equipment Specific examples and background material Useful reference material This manual is intended for residential HVAC contractors and installers as well as residential builders developers and architects It may also be useful to code officials and even discerning and technically savvy homeowners real estate agents and home appraisal professionals This manual is written in clear direct language making it understandable to professionals and laymen alike Standard 62.2 User's Manual is an essential supplement for professionals concerned with ventilation and indoor air quality in residences Use it alongside your copy of ANSI ASHRAE Standard 62.2 2016 In addition to offering immediate access to the content the PDF download of this standard presents selected graphics in color for enhanced readability

American Artisan, 1916 **Heating Handbook, a Manual of Standards, Codes, and Methods** Robert Henderson Emerick, 1964 **Heating and Air Conditioning: Standards, Codes, and Publications** David Craik Choate, 1957 **Manual J - Residential Load Calculation** Hank Rutkowski, 2011-11-01 Manual J 8th Edition is the national ANSI recognized standard for producing HVAC equipment sizing loads for single family detached homes small multi unit structures condominiums town houses and manufactured homes This new version incorporates the complete Abridged Edition of Manual J The manual provides quick supplemental details as well as supporting reference tables and appendices A proper load calculation performed in accordance with the Manual J 8th Edition procedure is required by national building codes and most state and local jurisdictions

**2019 ASHRAE Handbook**, 2019 Manual for the Balancing and Adjustment of Air Distribution Systems Sheet Metal and Air Conditioning Contractors' National Association. Air Balancing Manual Committee, 1967

**Massachusetts Uniform State Plumbing Code** Commonwealth Of Massachusetts, 2021-04-09 This book contains Massachusetts Uniform State Plumbing Code 248 CMR for the all plumbing related codes for the Commonwealth of Massachusetts

chapter 15 milady theory book flashcards quizlet - Mar 18 2023

web 1 77 flashcards learn test match q chat created by heather dawn penton scalp care shampooing conditioning theory book terms in this set 77 one of the most important experiences that a stylist provides is the shampoo the shampoo service actually encompasses three different processes scalp care massage shampooing conditioning

**read pdf milady's standard cosmetology theory practical** - May 20 2023

web aug 27 2020 milady's standard cosmetology theory practical workbook answer key format file ebook pdf epub mobi pocket audiobook txt doc ppt jpeg chm xml azw pdb kf8 prc tpz link download read online click next page milady's standard

cosmetology theory practical workbook answer key book detail

**milady s standard cosmetology theory practical workbook answer key** - Dec 03 2021

web milady s standard cosmetology theory practical workbook answer key january 2008 milady publishing 1562539035 9781562539030 aaaa not in library libraries near you worldcat 3 milady s standard cosmetology theory practical workbook answer key 2008 milady a part of cengage learning

[milady standard cosmetology practical workbook](#) - Jul 22 2023

web milady standard cosmetology practical workbook publication date 2016 topics beauty culture beauty culture examinations questions etc beauty operators examinations questions etc publisher boston ma milady cengage learning collection

**milady s standard cosmetology theory practical workbook answer key** - Feb 17 2023

web jan 1 2004 milady s standard cosmetology theory practical workbook answer key anonymous on amazon com free shipping on qualifying offers

[milady practical workbook answers](#) - May 08 2022

web jun 13 2023 milady practical workbook answer key answers for 2023 exams milady is the premier source for educational materials in cosmetology barbering esthetics nail technology and more answer keys to review tests and student workbooks test bank to create tests and quizzes

**answers miladys standard theory abebooks** - Aug 11 2022

web miladys standard cosmetology theory practical workbook answer key anonymous published by thomson delmar learning 2004 isbn 10 1562539035 isbn 13 9781562539030 seller read dream saint louis mo u s a seller rating contact seller book used softcover condition acceptable us 68 35 convert currency

**chapter 1 milady workbook flashcards quizlet** - Apr 19 2023

web chapter 1 milady workbook flashcards quizlet 4 6 5 reviews get a hint a term used to encompass the broad range of specialty areas including hairstyling nail technology and esthetics is click the card to flip cosmetology click the card to flip 1 54 flashcards learn test match q chat created by ava krempasky8

**milady s standard cosmetology theory practical workbook answer key** - Sep 12 2022

web find many great new used options and get the best deals for milady s standard cosmetology theory practical workbook answer key paperback at the best online prices at ebay free shipping for many products

**milady cosmetology workbook answer key answers for 2023** - Jun 21 2023

web pdf milady practical workbook answer key medair bookmark file pdf milady practical workbook answer key updated for easier use with the 2004 edition of milady s standard cosmetology the course management guide contains all the materials

educators need in print version or cd rom

*chapter 12 milady workbook answers muzing org* - Jan 04 2022

web sep 17 2023 exploring the key concepts in chapter 12 milady workbook answers chapter 12 of the milady workbook covers haircoloring basics like hair structure pigments and types of haircolor products it also explains color theory including the color wheel and formulation principles

*milady s standard cosmetology theory practical workbook answer key* - Jul 10 2022

web may 19 2006 milady s standard cosmetology theory practical workbook answer key milady 1 ratings by goodreads isbn 10 1562539035 isbn 13 9781562539030 published by milady publishing 2004 01 2004 used condition good soft cover save for later from lost books austin tx u s a abebooks seller since may 19 2006

**milady chapter 5 practical workbook answer key answers for** - Nov 14 2022

web download milady chapter 5 practical workbook answer key filename speed downloads milady chapter 5 practical workbook answer key added by users 5496 kb s 4267 milady chapter 5 practical workbook answer key new 4494 kb s 3675 milady chapter 5 practical workbook answer key added by request 3576 kb s 4080

practical workbook milady pdfdrive pdf c chapter 20 - Oct 13 2022

web 1 in your own words explain why cosmetologists should study and thoroughly understand chemical texture services 2 are hair services that cause chemical changes that alter the hair s natural wave pattern 3 identify some chemical texture services a b c 120 chapter 20 chemical texture services the structure of hair 4

**answers to milady s standard practical workbook goodreads** - Feb 05 2022

web jan 1 1995 answers to milady s standard practical workbook milady publishing company staff 0 00 0 ratings 0 reviews 273 pages paperback first published january

*milady practical workbook answer key answers for 2023 exams* - Aug 23 2023

web milady practical workbook answer key download milady practical workbook answer key filename speed downloads milady practical workbook answer key updated 1326 kb s 17 milady practical workbook answer key added by users 5553 kb s 3836 milady practical workbook answer key 3123 kb s 3875 milady practical workbook

**milady answer key for professional instructor m23** - Apr 07 2022

web milady answer key for professional instructor m2332 spa salon price 125 10 shop for more milady products product code vo 224861 qty description milady answer key for professional instructor welcome to the world of beauty and relaxation as a spa or salon professional you understand the importance of using only

e book download milady s standard cosmetology theory practical - Dec 15 2022

web pdf download milady s standard cosmetology theory practical workbook answer key ebook read online link read

download and more info

[milady s standard cosmetology theory practical workbook answer key](#) - Jan 16 2023

web jan 1 2004 milady s standard cosmetology theory practical workbook answer key anonymous 2 00 1 rating0 reviews for some reason this book has the same isbn number as another title from the series 1562539035 the other is spiral bound but this one has regular softcover binding

**milady answer key for professional instructor answers for** - Jun 09 2022

web acces pdf milady cosmetology answer key webshots standard professional barbering milady pass the state board instructor exam milady cosmetology answer key learn milady standard page 13 41

[milady s standard cosmetology theory practical workbook answer key](#) - Sep 24 2023

web may 4 2010 milady s standard cosmetology theory practical workbook answer key by milady 4 50 2 ratings 161 want to read 10 currently reading 5 have read

**milady test answer key answers for 2023 exams** - Mar 06 2022

web milady answer key milady is the premier source for educational materials in cosmetology barbering esthetics nail technology and more get support answer key for workbooks isbn 9781285769677 cd isbn 9780357481493 online access 10 codes list price 551 90 usd instructor support slides

*publisher dale seymour publications open library* - Jul 05 2022

answers for dale seymour publications puzzles answers for dale seymour publications puzzles 2 downloaded from learn copyblogger com on 2021 08 15 by guest 1999 01 54

**favorite problems seymour dale 9780866510851** - Jun 04 2022

jun 10 2023 this dale seymour publications answers word challenges as one of the majority functioning sellers here will totally be paired with by the best choices to review

*dale seymour publications answers word challenges 2022* - Nov 09 2022

dale seymour publications answers word challenges pdf pdf dale seymour publications answers word challenges pdf pdf you most likely know already that dale seymour

[dale seymour publications answers word challenges pdf pdf](#) - Oct 08 2022

this dale seymour publications answers word challenges can be taken as without difficulty as picked to act dale seymour publications answers word challenges downloaded from

*dale seymour publications answers word challenges* - Feb 12 2023

dale seymour publications answers word challenges 1 1 downloaded from coe fsu edu on october 1 2023 by guest read online dale seymour publications answers word



[dale seymour publications answers word challenges](#) - Oct 28 2021

*dale seymour publications answers word challenges pdf* - Aug 06 2022

mathematics study and teaching elementary problems exercises general education teaching study and teaching study and teaching primary geometry study and teaching secondary

**dale seymour publications answers word challenges test** - Nov 28 2021

**1984 by dale seymour publications factoring answers full pdf** - Dec 10 2022

without difficulty as perception of this dale seymour publications answers word challenges can be taken as competently as picked to act dale seymour publications answers word

*dale seymour publications answers word challenges* - Apr 02 2022

sep 4 2023 here are some recent wordle solutions september 9 lucky september 8 rouse september word challenge answers gameanswer jun 12 2023 word challenge answers b

[answers for dale seymour publications puzzles](#) - May 03 2022

unveiling the magic of words a report on 1983 dale seymour publications plexers answers in a world defined by information and interconnectivity the enchanting power of

*pdf answers for dale seymour publications puzzles* - Jul 17 2023

answers for dale seymour publications puzzles word challenges for sharp minds nov 06 2021 this collection offers 65 challenges to puzzle over think up transform and unravel

[books by dale seymour publications goodreads](#) - Sep 19 2023

dale seymour publications has 231 books on goodreads with 2424 ratings dale seymour publications s most popular book is mathematicians are people too

**dale seymour publications answers ministry of education** - Dec 30 2021

answers word challengesdale seymour publications answers puzzle 1 answers to the puzzle 2 crossmatics answers turn idle time into fun time with 72 word search puzzles just

**1983 dale seymour publications plexers answers** - Mar 01 2022

dale seymour publications answers 1 1 map index pdf dale seymour publications answers answers are included word challenges for sharp minds larry j zembala 1997 02 this

[online library dale seymour publications answers word](#) - Jan 31 2022

jun 18 2023 acquire this dale seymour publications answers word challenges after obtaining bargain in the dwelling

business premises or potentially in your technique can be

[dale seymour publications abebooks](#) - Jan 11 2023

rated at three levels of difficulty for students in grades 7 12 the activities provide experience with patterns with numbers shapes and letters ordering by size comparing shapes and designs

**dale seymour publications answers word challenges** - Apr 14 2023

2 dale seymour publications answers word challenges 2020 11 17 our common point new book the falling of the american empire 21st century medicine and the reversal of

**dale seymour publications answers word challenges copy** - May 15 2023

answers to dale seymour download dale seymour publications answers word challenges authors of the bestselling plexers and more plexers come three new books to

[dale seymour publications answers word challenges 2022](#) - Sep 07 2022

dale seymour publications answers word challenges whispering the techniques of language an psychological quest through dale seymour publications answers word

*amazon com dale seymour publications books* - Mar 13 2023

amazon com dale seymour publications books online shopping from a great selection at books store skip to main content us delivering to lebanon 66952 choose location for

[dale seymour publications answers word challenges pdf](#) - Jun 16 2023

dale seymour publications answers word challenges pdf dale seymour publications answers word challenges pdf is available in our book collection an online access to it is set

**dale seymour open library** - Aug 18 2023

sep 8 2008 april 1 2008 created by an anonymous user initial import author of eye cue puzzles getting smarter every day problem parade line designs favorite problems

**me and you you and me lyrics video youtube** - Sep 26 2022

web feb 13 2014 it s two in one you and me don t ever let go of what s beloved you are love itself therefore you and me you and me you and me lovey dovey as a result of loving as a

**jennie you me lyrics genius lyrics** - Jul 05 2023

web sep 8 2014 rose ave the debut album from you me available now download on itunes smarturl it roseave iqid ytstream rose ave on spotify smarturl it r

*you me you and me lyrics genius lyrics* - Nov 28 2022

web oct 22 2011 song composed by michael v arranged by albert tamayodirected by treb monterasartist d wonderboysfrom

bubble gangust satallite zoom effect1

**nitrous oxide daily use of laughing gas left me in a wheelchair** - Nov 16 2021

web 1 day ago 1 21 hours after hamas attacked israel on oct 7 news reports revealed that more than 200 people had been taken as hostages they include women and children young adults at a concert and people

**you me review you can t fail to love this deftly written** - Jan 19 2022

web nov 09 2023 6 00 am each week prudie discusses a tricky letter with a colleague or friend just for slate plus members this week jenée desmond harris discusses her response to in sickness

**b b king you and me me and you lyrics genius lyrics** - Sep 07 2023

web you and me me and you lyrics you took me way back in the country you fed me on love and greens you laid my head upon a feather bed and i sure had some mighty sweet dreams don t

*you me me 2023 mydramalist* - Aug 06 2023

web oct 6 2023 you me lyrics you know i gotcha you know that i got you like that ain t nobody gonna have your back like the way i do you love it just say you do you know you got me

yelawolf you and me official video youtube - Aug 26 2022

web sep 13 2012 pre ub40 you and me titles only and crow

**you and me bbc titles 1983 youtube** - Jun 23 2022

web you me is a new relationship drama set to air on itv it s written by newcomer jamie davis and produced by itv studios label happy prince the series has been described as a romantic comedy that has the hooks and twists of a thriller

*tureng me and you türkçe İngilizce sözlük* - Mar 01 2023

web you and me youtube music sign in 0 00 0 00 provided to youtube by universal music group you and me lifehouse lifehouse 2005 geffen records released on 2005 03 22 producer

you and me chords by you me p nk ultimate guitar com - May 23 2022

web it was like that for you and me before all this bütün bunlardan önce senin ve benim için de böyleydi then let s finish it you and me right here bu işi bitirelim sen ve ben tam burada okay it s just you and me lady evet sadece sen ve ben varız bayan we ll see a

you me start date plot cast and everything you need to know - Apr 21 2022

web you and me türkçesi you and me nedir sen ve ben İkimiz you and me ile ilgili cümleler english i want for you and me to be happy turkish İkimizin mutlu olmasını istiyorum english ali wants to see you and me turkish ali seni ve beni görmek istiyor english i

**kenny chesney me and you official video youtube** - Apr 02 2023

web me and you teriminin diđer terimlerle kazandıđı İngilizce türkçe sözlükte anlamları 79 sonuç İngilizce türkçe online sözlük tureng kelime ve terimleri çevir ve farklı aksanlarda sesli dinleme tell me who you go with and i ll tell you who you are bana arkadaşını

[walmart s black friday deals are here ps5 apple watch and](#) - Jul 13 2021

**you and me ne demek ile ilgili org** - Feb 17 2022

web 1 day ago a woman who took almost 100 cannisters of laughing gas a day says she has been left with permanent nerve damage kerry anne donaldson 26 and from east london first started using nitrous oxide

**jenée desmond harris and joel anderson discuss a letter about** - Oct 16 2021

web published november 8 2023 photos wirecutter staff walmart has launched its early black friday sale offering discounts on a variety of electronics toys and housewares the retailer continued

**you me tv mini series 2023 imdb** - Dec 18 2021

web 9 hours ago knowing you want to change is a good sign writes advice columnist eleanor gordon smith i have this compelling drive to improve others that most times ends with me in trouble as others don

*my drive to improve others makes me a never pleased father* - Sep 14 2021

web tureng dictionary and translation ltd tureng Çok dilli sözlük size İngilizce fransızca almanca İspanyolca ve türkçe terimleri arayabileceđiniz kapsamlı bir sözlük hizmeti sunmaktadır

**tureng you and me türkçe İngilizce sözlük** - Jun 11 2021

**israel hamas images have me reliving trauma i was a hostage** - Aug 14 2021

**you and me türkçe çeviri örnekler İngilizce reverso context** - Mar 21 2022

web feb 23 2023 intensely cute harry lawtey and sophia brown in you me photograph itv studios emma is a young actor who is about to star in a much hyped new play fulfilling her wildest dreams

*lifehouse you and me official music video youtube* - Oct 08 2023

web dec 20 2009 remastered in hd official music video for you and me performed by lifehouse follow lifehouse instagram instagram com lifehousetwitter

[therefore you and me ft hatsune genius](#) - Jul 25 2022

web jun 20 2016 you and me by you me album rose ave track 5 2014 standard tuning capo on the 4th fret chords am x02210 f x33211 or 133211 g 320003 or 320033 c x32010 em x22000 to play without a

[you me you and me official lyric video youtube](#) - Jun 04 2023

web become a better singer in only 30 days with easy video lessons you took me way back in the country you fed me on love and greens you laid my head upon a feather bed and i sure had some mighty sweet dreams don t you know we got something going on you

[b b king you and me me and you lyrics lyrics com](#) - May 03 2023

web nov 24 2009 official video for me and you by kenny chesneylisten kenny chesney kennychesney lnk to listenyd subscribe to kenny s

**you and me youtube music** - Jan 31 2023

web sep 8 2014 verse 1 you and me were always with each other before we knew the other was ever there you and me we belong together just like a breath needs the air i told if you if you called i

**lifehouse you and me lyrics genius lyrics** - Dec 30 2022

web nov 13 2014 guiding your direction when you re riding through the dark senin yönüne yönelir sen geceye doğru sürerken oh that s you and me bu sen ve ben that s you and me bu sen ve ben you me Şarkı Çevirileri you and me you and me were always

**you me you and me Şarkı Çevirisi alternatifim** - Oct 28 2022

web jan 17 2020 68m views 5 years ago yelawolf you and me official video don t forget to subscribe for more music youtube com yelawolfofficial stream ghetto cowboy visit

Uncover the mysteries within Crafted by is enigmatic creation, **American Standard Air Handler Manual** . This downloadable ebook, shrouded in suspense, is available in a PDF format ( Download in PDF: \*). Dive into a world of uncertainty and anticipation. Download now to unravel the secrets hidden within the pages.

[https://offsite.creighton.edu/files/virtual-library/Documents/god\\_of\\_war\\_oracle\\_puzzle.pdf](https://offsite.creighton.edu/files/virtual-library/Documents/god_of_war_oracle_puzzle.pdf)

[https://offsite.creighton.edu/files/virtual-library/Documents/gace\\_business\\_education\\_study\\_guide.pdf](https://offsite.creighton.edu/files/virtual-library/Documents/gace_business_education_study_guide.pdf)

[https://offsite.creighton.edu/files/virtual-library/Documents/gabys\\_latin\\_american\\_kitchen.pdf](https://offsite.creighton.edu/files/virtual-library/Documents/gabys_latin_american_kitchen.pdf)

## **Table of Contents American Standard Air Handler Manual**

1. Understanding the eBook American Standard Air Handler Manual
  - The Rise of Digital Reading American Standard Air Handler Manual
  - Advantages of eBooks Over Traditional Books
2. Identifying American Standard Air Handler Manual
  - Exploring Different Genres
  - Considering Fiction vs. Non-Fiction
  - Determining Your Reading Goals
3. Choosing the Right eBook Platform
  - Popular eBook Platforms
  - Features to Look for in an American Standard Air Handler Manual
  - User-Friendly Interface
4. Exploring eBook Recommendations from American Standard Air Handler Manual
  - Personalized Recommendations
  - American Standard Air Handler Manual User Reviews and Ratings

- American Standard Air Handler Manual and Bestseller Lists
- 5. Accessing American Standard Air Handler Manual Free and Paid eBooks
  - American Standard Air Handler Manual Public Domain eBooks
  - American Standard Air Handler Manual eBook Subscription Services
  - American Standard Air Handler Manual Budget-Friendly Options
- 6. Navigating American Standard Air Handler Manual eBook Formats
  - ePub, PDF, MOBI, and More
  - American Standard Air Handler Manual Compatibility with Devices
  - American Standard Air Handler Manual Enhanced eBook Features
- 7. Enhancing Your Reading Experience
  - Adjustable Fonts and Text Sizes of American Standard Air Handler Manual
  - Highlighting and Note-Taking American Standard Air Handler Manual
  - Interactive Elements American Standard Air Handler Manual
- 8. Staying Engaged with American Standard Air Handler Manual
  - Joining Online Reading Communities
  - Participating in Virtual Book Clubs
  - Following Authors and Publishers American Standard Air Handler Manual
- 9. Balancing eBooks and Physical Books American Standard Air Handler Manual
  - Benefits of a Digital Library
  - Creating a Diverse Reading Collection American Standard Air Handler Manual
- 10. Overcoming Reading Challenges
  - Dealing with Digital Eye Strain
  - Minimizing Distractions
  - Managing Screen Time
- 11. Cultivating a Reading Routine American Standard Air Handler Manual
  - Setting Reading Goals American Standard Air Handler Manual
  - Carving Out Dedicated Reading Time
- 12. Sourcing Reliable Information of American Standard Air Handler Manual
  - Fact-Checking eBook Content of American Standard Air Handler Manual
  - Distinguishing Credible Sources

13. Promoting Lifelong Learning
  - Utilizing eBooks for Skill Development
  - Exploring Educational eBooks
14. Embracing eBook Trends
  - Integration of Multimedia Elements
  - Interactive and Gamified eBooks

### **American Standard Air Handler Manual Introduction**

Free PDF Books and Manuals for Download: Unlocking Knowledge at Your Fingertips In today's fast-paced digital age, obtaining valuable knowledge has become easier than ever. Thanks to the internet, a vast array of books and manuals are now available for free download in PDF format. Whether you are a student, professional, or simply an avid reader, this treasure trove of downloadable resources offers a wealth of information, conveniently accessible anytime, anywhere. The advent of online libraries and platforms dedicated to sharing knowledge has revolutionized the way we consume information. No longer confined to physical libraries or bookstores, readers can now access an extensive collection of digital books and manuals with just a few clicks. These resources, available in PDF, Microsoft Word, and PowerPoint formats, cater to a wide range of interests, including literature, technology, science, history, and much more. One notable platform where you can explore and download free American Standard Air Handler Manual PDF books and manuals is the internet's largest free library. Hosted online, this catalog compiles a vast assortment of documents, making it a veritable goldmine of knowledge. With its easy-to-use website interface and customizable PDF generator, this platform offers a user-friendly experience, allowing individuals to effortlessly navigate and access the information they seek. The availability of free PDF books and manuals on this platform demonstrates its commitment to democratizing education and empowering individuals with the tools needed to succeed in their chosen fields. It allows anyone, regardless of their background or financial limitations, to expand their horizons and gain insights from experts in various disciplines. One of the most significant advantages of downloading PDF books and manuals lies in their portability. Unlike physical copies, digital books can be stored and carried on a single device, such as a tablet or smartphone, saving valuable space and weight. This convenience makes it possible for readers to have their entire library at their fingertips, whether they are commuting, traveling, or simply enjoying a lazy afternoon at home. Additionally, digital files are easily searchable, enabling readers to locate specific information within seconds. With a few keystrokes, users can search for keywords, topics, or phrases, making research and finding relevant information a breeze. This efficiency saves time and effort, streamlining the learning process and allowing individuals to focus on extracting the information they need. Furthermore, the availability of free PDF books and manuals fosters a culture



of continuous learning. By removing financial barriers, more people can access educational resources and pursue lifelong learning, contributing to personal growth and professional development. This democratization of knowledge promotes intellectual curiosity and empowers individuals to become lifelong learners, promoting progress and innovation in various fields. It is worth noting that while accessing free American Standard Air Handler Manual PDF books and manuals is convenient and cost-effective, it is vital to respect copyright laws and intellectual property rights. Platforms offering free downloads often operate within legal boundaries, ensuring that the materials they provide are either in the public domain or authorized for distribution. By adhering to copyright laws, users can enjoy the benefits of free access to knowledge while supporting the authors and publishers who make these resources available. In conclusion, the availability of American Standard Air Handler Manual free PDF books and manuals for download has revolutionized the way we access and consume knowledge. With just a few clicks, individuals can explore a vast collection of resources across different disciplines, all free of charge. This accessibility empowers individuals to become lifelong learners, contributing to personal growth, professional development, and the advancement of society as a whole. So why not unlock a world of knowledge today? Start exploring the vast sea of free PDF books and manuals waiting to be discovered right at your fingertips.

### **FAQs About American Standard Air Handler Manual Books**

How do I know which eBook platform is the best for me? Finding the best eBook platform depends on your reading preferences and device compatibility. Research different platforms, read user reviews, and explore their features before making a choice. Are free eBooks of good quality? Yes, many reputable platforms offer high-quality free eBooks, including classics and public domain works. However, make sure to verify the source to ensure the eBook credibility. Can I read eBooks without an eReader? Absolutely! Most eBook platforms offer webbased readers or mobile apps that allow you to read eBooks on your computer, tablet, or smartphone. How do I avoid digital eye strain while reading eBooks? To prevent digital eye strain, take regular breaks, adjust the font size and background color, and ensure proper lighting while reading eBooks. What the advantage of interactive eBooks? Interactive eBooks incorporate multimedia elements, quizzes, and activities, enhancing the reader engagement and providing a more immersive learning experience. American Standard Air Handler Manual is one of the best book in our library for free trial. We provide copy of American Standard Air Handler Manual in digital format, so the resources that you find are reliable. There are also many Ebooks of related with American Standard Air Handler Manual. Where to download American Standard Air Handler Manual online for free? Are you looking for American Standard Air Handler Manual PDF? This is definitely going to save you time and cash in something you should think about. If you trying to find then search around for online. Without a doubt there are numerous these available and many of them have

the freedom. However without doubt you receive whatever you purchase. An alternate way to get ideas is always to check another American Standard Air Handler Manual. This method for see exactly what may be included and adopt these ideas to your book. This site will almost certainly help you save time and effort, money and stress. If you are looking for free books then you really should consider finding to assist you try this. Several of American Standard Air Handler Manual are for sale to free while some are payable. If you arent sure if the books you would like to download works with for usage along with your computer, it is possible to download free trials. The free guides make it easy for someone to free access online library for download books to your device. You can get free download on free trial for lots of books categories. Our library is the biggest of these that have literally hundreds of thousands of different products categories represented. You will also see that there are specific sites catered to different product types or categories, brands or niches related with American Standard Air Handler Manual. So depending on what exactly you are searching, you will be able to choose e books to suit your own need. Need to access completely for Campbell Biology Seventh Edition book? Access Ebook without any digging. And by having access to our ebook online or by storing it on your computer, you have convenient answers with American Standard Air Handler Manual To get started finding American Standard Air Handler Manual, you are right to find our website which has a comprehensive collection of books online. Our library is the biggest of these that have literally hundreds of thousands of different products represented. You will also see that there are specific sites catered to different categories or niches related with American Standard Air Handler Manual So depending on what exactly you are searching, you will be able tochoose ebook to suit your own need. Thank you for reading American Standard Air Handler Manual. Maybe you have knowledge that, people have search numerous times for their favorite readings like this American Standard Air Handler Manual, but end up in harmful downloads. Rather than reading a good book with a cup of coffee in the afternoon, instead they juggled with some harmful bugs inside their laptop. American Standard Air Handler Manual is available in our book collection an online access to it is set as public so you can download it instantly. Our digital library spans in multiple locations, allowing you to get the most less latency time to download any of our books like this one. Merely said, American Standard Air Handler Manual is universally compatible with any devices to read.

### **Find American Standard Air Handler Manual :**

**god of war oracle puzzle**

**gace business education study guide**

[gaby's latin american kitchen](#)

[geometry 1 textbook](#)

**gibbs reflective cycle nursing**

*gator lending contract*

*gnostic bible books*

**geometry for dummies online**

girl scout campfire stew

goggins book can't hurt me

gmc truck with allison transmission

**gargoyle vs grotesque**

**giselle lab rats**

glencoe math course 2 volume 1 answer key pdf

*glendale volunteer fire department*

**American Standard Air Handler Manual :**