

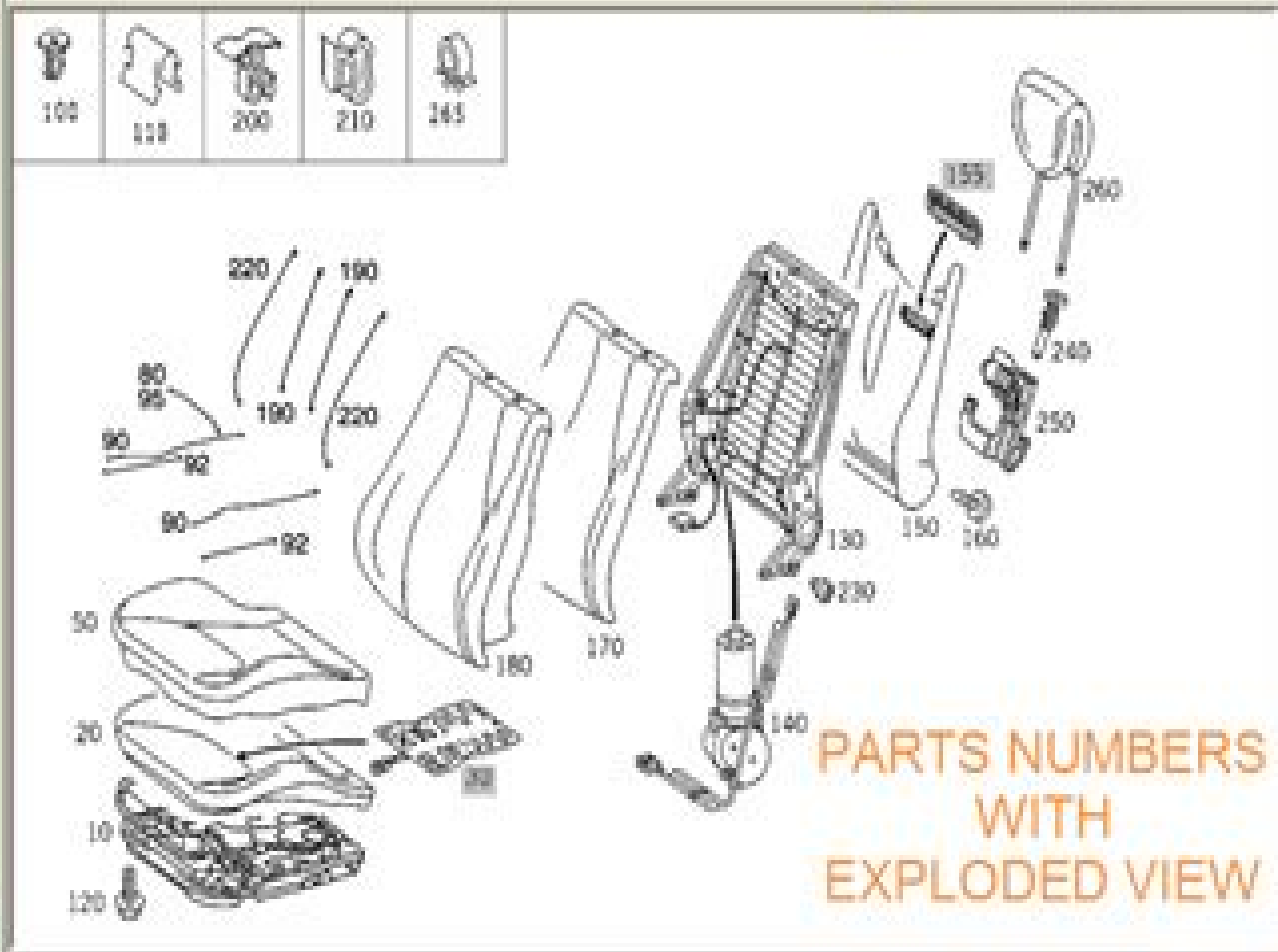

✓	Item	Part number	Designation/Description
<input type="checkbox"/>	10	A 220 910 03 22	CUSHION FRAME LEFT BOM From Chassis
<input type="checkbox"/>	20	A 220 910 02 50	REST LEFT SEAT BOM From Chassis Code: 401
<input type="checkbox"/>	50	A 220 910 05 46 8072	COVER LEATHER TRIM LEFT BOM From Chassis Code: 2706
<input type="checkbox"/>	80	A 460 924 00 29	CLAMP CROSS STAPLE UPHOLSTE LEFT SEAT 205PH
<input type="checkbox"/>	90	A 220 914 05 29	CLAMP LONGITUDINAL STAPLE LI OUT. LEFT/RIGHT, LEFT S BOM From Chassis
<input type="checkbox"/>	92	A 460 924 00 29	CLAMP LONGITUDINAL STAPLE LI CENTER LEFT SEAT 205PH
<input type="checkbox"/>	95	A 203 914 03 29	CLAMP CROSS STAPLE FRONT 20
<input type="checkbox"/>	100	A 006 968 09 78	CLIP STAPLE CUSHION BACK, L
<input type="checkbox"/>	110	A 006 968 12 78	CLIP UPHOLSTERY FO-CUSHION
<input type="checkbox"/>	120	N 924130 006006	SCREW LEFT SEAT CUSHION AT 5.7



Mercedes Parts Manual

Frank Barrett



Mercedes Parts Manual

Mercedes-Benz Technical Companion Bentley Publishers, Mercedes-Benz Club of America, 2005 Technical insights on service repair maintenance and procedures compiled from over 45 years of The Star the magazine of the Mercedes Benz Club of America Since 1956 informed Mercedes Benz owners have relied upon The Star the magazine of the Mercedes Benz Club of America for advice about maintenance service and repair of their cars Bentley Publishers has collected some of the best of these do it yourself articles and tech tips into the Mercedes Benz Technical Companion No matter which Mercedes Benz model you drive or desire this compilation will serve as a valuable technical reference to help you understand and care for your Mercedes Benz This insightful and informed technical compilation has something for the Mercedes Benz owner service professional and enthusiast You will also find useful technical guidance that pertains to Mercedes Benz vehicles in general based on the contributors long time dedication to Mercedes Benz service and ownership

Mercedes-Benz Buyer's Guide Fred Larimer, This book gives an up close look at Mercedes Benz roadsters convertibles and two and four seat coupes from the mid 1950s to present With roadsters starting with the 300SL s from the mid 1950 and continuing through the current SLK s up to the 2003 model year Coupes and Cabrios this book details the 220SEb 300SE cars of 1960 and continues on up to the current CLK s to the 2003 model year This approach better serves those who are in the market for personal cars by not spreading the book too thin to cover the entire Mercedes Benz lineup Explore all the traditional elements of the Buyer s Guide series such as the basic histories of each model or model type Garage Watch photos with inset photo callouts tables of common replacement parts quotes from contemporary magazine reviews owner testimonials rating charts and specification tables

Mercedes-Benz Repair and Tune-Up Guide Motorbooks International, 1987-08 Reprint of a Glenn s manual covering repairs to 180 190 200 219 220 230 250 300 and 600 models Includes performance and mechanical specs wiring diagrams and selected Road Track road tests Pub 1966

Mercedes-Benz C-Class 2001 thru 2007 Editors of Haynes Manuals, 2009-10-01 Haynes manuals are written specifically for the do it yourselfer yet are complete enough to be used by professional mechanics Since 1960 Haynes has produced manuals written from hands on experience based on a vehicle teardown with hundreds of photos and illustrations making Haynes the world leader in automotive repair information

Mercedes-Benz 124 Series ('85 to '93) Service and Repair Manual Spencer J. Drayton, Mark Coombs, Steve Rendle, 1996 200 230 250 260 280 300 320 Saloon Estate Coupe 124 Series with rear wheel drive Does NOT cover Convertible Limousine 4x4 or E Class range introduced August 1993 Petrol 2 0 litre 1996cc 2 3 litre 2298cc 2 6 litre 2597cc 2 8 litre 2799cc 3 0 litre 2962cc 3 2 litre 3199cc Does NOT cover 4 cyl 16 valve or V8 petrol engines Diesel turbo Diesel 2 0 litre 1997cc 2 5 litre 2497cc 3 0 litre 2996cc

Mercedes W123, 1976-86 Brooklands Books, Brooklands Books Ltd, 1993-02 The only manual written especially for the owners of both 4 and 6 cylinder engines that powered the 200 230

230E 250 280 280E from 1976 1986 Engines electrics transmission brakes a complete manual *Mercedes-Benz W126 S-Class 1979-1991* Nik Greene,2019-02-18 The Mercedes 126 S Class of 1979 1991 remains the most successful premium saloon in the company's history and is considered by many to be one of the best cars in the world You don't simply decide to buy an S Class it comes to you when fate has ordained that your life should take that course The door closes with a reassuring clunk and you have arrived said the sales brochure of the first real Sonderklasse the W116 With over 300 colour photos and production histories and specifications for both Generation One and Two models this is an essential resource for anyone with an interest in this timeless car The book covers an overview of the key personalities who drove the development of this model the initial 116 Sonderklasse and its subsequent evolution the history and personality of each model and finally detailed analysis of the different engines both petrol and diesel This essential resource explores both the technical and social sides of how this legend was born and is superbly illustrated with 314 colour photographs [Mercedes E Class Petrol](#)

[Workshop Manual W210 & W211 Series](#) Gordon Lund,2012-10-14 This Owners Edition Workshop Manual covers the Mercedes Benz E Class Diesel W210 W211 Series from 2000 to 2006 fitted with the 1 8 2 0 2 6 2 8 3 2 3 5 4 3 5 0 Litre 111 112 113 271 272 with four six eight cylinder petrol engine It has been specially written for the practical owner who wants to maintain a vehicle in first class condition and carry out the bulk of his or her own servicing and repairs Comprehensive step by step instructions are provided for service and overhaul operations to guide the reader through what might otherwise be unfamiliar and complicated tasks Numerous drawings are included to amplify the text With 190 pages well illustrated

Mercedes-Benz 300 SL Hans Kleissl,Harry Niemann,2021-06 A lavishly illustrated tribute to one of the most beloved European cars of all time For nearly seventy years no car has moved the lovers of classic cars more than the 300 SL A legend since its launch in 1954 as a gullwing coupe the 300 SL has been seen as the very model of what a sports car can be its style and beauty perfectly matched to its power and handling This beautifully illustrated tribute volume brings together Hans Kleissl one of the world's leading experts on the 300 SL and former Daimler historian and Mercedes Benz archive manager Harry Niemann The resulting book captures the magic and mystique of the car through history photographs insights into its technological breakthroughs and firsthand accounts of its storied run There's no better gift for the passionate fan of the 300 SL [Vehicle Operator's Manual](#) ,1988 [Marine Diesel Basics 1](#) Dennison Berwick,2017-05-11 Seeing is Understanding

The first VISUAL guide to marine diesel systems on recreational boats Step by step instructions in clear simple drawings explain how to maintain winterize and recommission all parts of the system fuel deck fill engine batteries transmission stern gland propeller Book one of a new series Canadian author is a sailor and marine mechanic cruising aboard his 36 foot steel hulled Chevrier sloop Illustrations 300 drawings Pages 222 pages Published 2017 Format softcover Category Inboards Gas Diesel [Mercedes-Benz E-class Owner's Bible, 1986-1995](#) Bentley Publishers,Bentley Publishers Staff,2002 This book is an E class buyer's guide maintenance handbook and technical reference source all wrapped into one It is full of tech tips service

hints and system descriptions plus lots of insightful information about the W124 E Class chassis This E Class Owner s Bible can help steer you through the purchase of your first Mercedes Benz provide the information necessary to maintain your E Class to factory standards give you the assurance to speak knowledgeably to your service professional and provide you with the hot setup for better road handling The prospective buyer will also find tips on what to watch out for why a pre purchase inspection is important and why one model may be preferred to another Do it Yourself owners will discover a huge hands on maintenance chapter to help keep their E Class at peak efficiency To bring you this authoritative volume Bentley Publishers has teamed up with Stu Ritter a 25 year independent Mercedes Benz repair shop owner technician and current technical editor of The Star the magazine of the Mercedes Benz Club of America

Mercedes Benz 124 Series Service and Repair Manual ,2013-05 This is a maintenance and repair manual for the DIY mechanic It covers the Mercedes Benz 124 series *Mercedes Benz & Dodge Sprinter CDI 2000-2006 Owners Workshop Manual* Various,Trade Trade,2012-10-14 Easy to follow step by step instructions advice which enables the owner to carry out many jobs himself for the Mercedes Benz Sprinter Van Camper Diesel Models covered 208 CDI 308 CDI 211 CDI 311 CDI 411 CDI 213 CDI 313 CDI 413 CDI 216 CDI 316 CDI 416 CDI with the 2 2 2 7 litre CDI Diesel types 611 DELA 612 DELA From 2000 to 2006 with the commom rail injection system A total of 232 fully illustrated pages

Mercedes-Benz Diesel 123 Series John Haynes,1988-04-01 With a Haynes manual you can do it yourself from simple maintenance to basic repairs Haynes writes every book based on a complete teardown of the vehicle We learn the best ways to do a job and that makes it quicker easier and cheaper for you Our books have clear instructions and plenty of photographs that show each step Whether you re a beginner or a pro you can save big with Haynes Step by step procedures Easy to follow photos Complete troubleshooting section Valuable short cuts Color spark plug diagnosis Complete coverage for your Mercedes Benz Diesel 123 Series covering all 200D 220D 240D 240TD 300D 300CD 300TD models designated W123 Series 4 cyl 5 cyl including turbo diesel 1976 thru 1985 Routine Maintenance Tune up procedures Engine repair Cooling and heating Air Conditioning Fuel and exhaust Emissions control Ignition Brakes Suspension and steering Electrical systems Wiring diagrams

Firebird Body Trim and Glass Interchangeable Parts Buyers Guide John R. Miller,2002-10 Interchangeable parts for 1967 1981 Firebird models Body trim glass and nameplates included

Illustrated Mercedes-Benz Buyer's Guide Frank Barrett,1994 Discusses the development history and specifications for all Mercedes Benz models from 1886 to the present

Motor Auto Repair Manual ,1979 Mercedes Benz 230, 250 and 280, 1968-1972 John Haynes,1987-07-30 Haynes disassembles every subject vehicle and documents every step with thorough instructions and clear photos Haynes repair manuals are used by the pros but written for the do it yourselfer

Mercedes-Benz Owners Workshop Manual A. K. Legg,2014 Models covered UK 250 and 250 long wheelbase Saloons 2525 cc 250 T Estate 2525 cc 280 and 280 E Saloons 2746 cc 280 TE Estate 2746 cc 280 C and 280 CE Coupes 2746 cc

The Essential Theatre by Brockett, Oscar G. - Amazon.com The Tenth Edition of THE ESSENTIAL THEATRE will inspire readers to become excited about theatre. The combined authorship of an authoritative theatre ... The Essential Theatre - Oscar Gross Brockett, Robert J. Ball The Tenth Edition of THE ESSENTIAL THEATRE will inspire readers to become excited about theatre. The combined authorship of an authoritative theatre ... The Essential Theatre by Oscar G. Brockett Robert J. Ball The Essential Theatre Review This The Essential Theatre book is not really ordinary book, you have it then the world is in your hands. The benefit you get by ... Amazon.com: The Essential Theatre, Enhanced FREE delivery December 28 - 29. Details. Arrives after Christmas. Need a gift ... Cengage Learning; 10th edition (March 28, 2013). Language, English. Paperback ... Here is a link to almost any textbook's free PDF version. : r/unt Need a pdf for Essential Cell Biology 6th edition isbn: 978-1-324 ... Introduction to the Practice of Statistics, 10th edition. By David S ... Editions of The Essential Theatre by Oscar Gross Brockett The Essential Theatre 10th Edition. Published January 1st 2011 by Cengage ... Goodreadswww.goodreads.comFREE - In Google Play. View. The Essential Theatre, 11th Edition - Cengage Hardcopy textbook for Brockett/Ball//Fleming/Carlson's The Essential Theatre. Buy direct for hassle-free returns. Included in Cengage Unlimited. free read [pdf] The Essential Theatre - YUMPU Sep 15, 2022 — The Eleventh Edition includes an all-new chapter devoted to musical theatre, new Then and Now boxes that link theatre history to present-day, ... [PDF] The Essential Theatre by Oscar Brockett eBook - Perlego The Eleventh Edition includes an all-new chapter devoted to musical theatre, new "Then and Now" boxes that link theatre history to present-day, and numerous new ... Got my Theatre textbook today, and look who's on ... - Reddit It's The Essential Theatre: Tenth Edition by Oscar G. Brockett and Robert J. Ball. The ISBN is 9780495807971 so you can find the exact edition. NRP 6th Ed. Super Set Flashcards Study with Quizlet and memorize flashcards containing terms like About ____% of newborns will require some assistance to begin regular breathing, ... NRP 6th Ed. Ch 1 Overview & Principles - Key Points Study with Quizlet and memorize flashcards containing terms like 1 most newly born babies vigorous. Only about 10 percent require some kind of assistance ... 2022 NRP Practice EXAM Questions AND Answers ALL ... 2022 NRP Practice EXAM Questions AND Answers ALL Solved Solution 2022 nrp practice exam questions and answers all solved solution your team has provided ... NRP 8th Edition Test Answers 2023 Apr 19, 2023 — NRP 8th Edition Test Answers 2023 ; What is the initial oxygen concentration for preterm newborns less than 35 weeks gestation? 21-30% ; What is ... nrp practice exam 2022_questions and answers all solved ... 2022 NRP PRACTICE EXAM QUESTIONS AND ANSWERS ALL SOLVED SOLUTION Your team has provided face-mask PPV with chest movement for 30 seconds. NRP Exam and answers.docx - Here is a table with ... Here is a table with answers to the Neonatal Resuscitation Practice 8th Edition exams and tests. QuestionAnswer Your team has provided face-mask PPVwith chest ... 2022 NRP Practice EXAM Questions AND Answers ALL ... 2022 NRP PRACTICE EXAM QUESTIONS AND. ANSWERS ALL SOLVED SOLUTION. Your team has provided face-mask PPV with chest movement for 30 seconds. NRP 8th Edition Quiz Answers Part 1 Pre assessment 2023 ...

Nrp Test Answers NRP 8th Edition Test Exams Questions with Answers(Latest Update):Complete Version ... 6th Grade Ccss Pacing Guide PDF Kindle. The NRP exam answers PDF for 2023 ... Annie John Annie John, a novel written by Jamaica Kincaid in 1985, details the growth of a girl in Antigua, an island in the Caribbean. It covers issues as diverse as ... Annie John: A Novel by Kincaid, Jamaica The essential coming-of-age novel by Jamaica Kincaid, Annie John is a haunting and provocative story of a young girl growing up on the island of Antigua. Annie John: Study Guide Annie John is a novel by Jamaica Kincaid that was first published in 1985. It is a coming-of-age story that follows the eponymous protagonist as she grows ... Annie John (Kincaid) - Literally a full book pdf Contents ... I was afraid of the dead, as was everyone I knew. We were afraid of the dead because we never could tell when they might show up again. Sometimes ... Annie John: Full Book Summary Annie suffers a mental breakdown that coincides with a three-month rainstorm and becomes bedridden. In her sickness, her behavior reverts to that of an infant. Annie John by Jamaica Kincaid Read 909 reviews from the world's largest community for readers. Annie John is a haunting and provocative story of a young girl growing up on the island of... Annie John, by Jamaica Kincaid by PJO Smith · 1995 — Principal characters: ANNIE VICTORIA JOHN, a precocious, vibrant, and fiercely independent young woman. MRS. ANNIE JOHN, Annie's loving but unpredictable ... Annie John The essential coming-of-age novel by Jamaica Kincaid, Annie John is a haunting and provocative story of a young girl growing up on the island of Antigua. Annie John: A Novel by Jamaica Kincaid, Paperback The essential coming-of-age novel by Jamaica Kincaid, Annie John is a haunting and provocative story of a young girl growing up on the island of Antigua. Book Review - Annie John by Jamaica Kincaid | Vishy's Blog Jun 16, 2022 — 'Annie John' is a beautiful coming-of-age story. I loved the beautiful, complex portrayal of the relationship between Annie and her mother. This ...

Adopting the Tune of Phrase: An Emotional Symphony within **Mercedes Parts Manual**

In a global taken by screens and the ceaseless chatter of fast conversation, the melodic beauty and mental symphony developed by the published word usually disappear in to the background, eclipsed by the relentless sound and interruptions that permeate our lives. Nevertheless, set within the pages of **Mercedes Parts Manual** a stunning literary prize brimming with natural emotions, lies an immersive symphony waiting to be embraced. Crafted by an elegant composer of language, that charming masterpiece conducts visitors on a psychological trip, skillfully unraveling the concealed tunes and profound impact resonating within each cautiously crafted phrase. Within the depths of the poignant evaluation, we can investigate the book is central harmonies, analyze its enthralling publishing style, and submit ourselves to the profound resonance that echoes in the depths of readers souls.

https://offsite.creighton.edu/files/virtual-library/Documents/jack_parsons_aleister_crowley.pdf

https://offsite.creighton.edu/files/virtual-library/Documents/ivan_most_dangerous_game.pdf

https://offsite.creighton.edu/files/virtual-library/Documents/is_geralds_game_a_true_story.pdf

Table of Contents Mercedes Parts Manual

1. Understanding the eBook Mercedes Parts Manual
 - The Rise of Digital Reading Mercedes Parts Manual
 - Advantages of eBooks Over Traditional Books
2. Identifying Mercedes Parts Manual
 - Exploring Different Genres
 - Considering Fiction vs. Non-Fiction
 - Determining Your Reading Goals

3. Choosing the Right eBook Platform
 - Popular eBook Platforms
 - Features to Look for in an Mercedes Parts Manual
 - User-Friendly Interface
4. Exploring eBook Recommendations from Mercedes Parts Manual
 - Personalized Recommendations
 - Mercedes Parts Manual User Reviews and Ratings
 - Mercedes Parts Manual and Bestseller Lists
5. Accessing Mercedes Parts Manual Free and Paid eBooks
 - Mercedes Parts Manual Public Domain eBooks
 - Mercedes Parts Manual eBook Subscription Services
 - Mercedes Parts Manual Budget-Friendly Options
6. Navigating Mercedes Parts Manual eBook Formats
 - ePub, PDF, MOBI, and More
 - Mercedes Parts Manual Compatibility with Devices
 - Mercedes Parts Manual Enhanced eBook Features
7. Enhancing Your Reading Experience
 - Adjustable Fonts and Text Sizes of Mercedes Parts Manual
 - Highlighting and Note-Taking Mercedes Parts Manual
 - Interactive Elements Mercedes Parts Manual
8. Staying Engaged with Mercedes Parts Manual
 - Joining Online Reading Communities
 - Participating in Virtual Book Clubs
 - Following Authors and Publishers Mercedes Parts Manual
9. Balancing eBooks and Physical Books Mercedes Parts Manual
 - Benefits of a Digital Library
 - Creating a Diverse Reading Collection Mercedes Parts Manual
10. Overcoming Reading Challenges
 - Dealing with Digital Eye Strain
 - Minimizing Distractions

- Managing Screen Time
- 11. Cultivating a Reading Routine Mercedes Parts Manual
 - Setting Reading Goals Mercedes Parts Manual
 - Carving Out Dedicated Reading Time
- 12. Sourcing Reliable Information of Mercedes Parts Manual
 - Fact-Checking eBook Content of Mercedes Parts Manual
 - Distinguishing Credible Sources
- 13. Promoting Lifelong Learning
 - Utilizing eBooks for Skill Development
 - Exploring Educational eBooks
- 14. Embracing eBook Trends
 - Integration of Multimedia Elements
 - Interactive and Gamified eBooks

Mercedes Parts Manual Introduction

Free PDF Books and Manuals for Download: Unlocking Knowledge at Your Fingertips In today's fast-paced digital age, obtaining valuable knowledge has become easier than ever. Thanks to the internet, a vast array of books and manuals are now available for free download in PDF format. Whether you are a student, professional, or simply an avid reader, this treasure trove of downloadable resources offers a wealth of information, conveniently accessible anytime, anywhere. The advent of online libraries and platforms dedicated to sharing knowledge has revolutionized the way we consume information. No longer confined to physical libraries or bookstores, readers can now access an extensive collection of digital books and manuals with just a few clicks. These resources, available in PDF, Microsoft Word, and PowerPoint formats, cater to a wide range of interests, including literature, technology, science, history, and much more. One notable platform where you can explore and download free Mercedes Parts Manual PDF books and manuals is the internet's largest free library. Hosted online, this catalog compiles a vast assortment of documents, making it a veritable goldmine of knowledge. With its easy-to-use website interface and customizable PDF generator, this platform offers a user-friendly experience, allowing individuals to effortlessly navigate and access the information they seek. The availability of free PDF books and manuals on this platform demonstrates its commitment to democratizing education and empowering individuals with the tools needed to succeed in their chosen fields. It allows anyone, regardless of their background or financial limitations, to expand their horizons and gain insights from experts in various disciplines. One of the most significant advantages of downloading PDF books and

manuals lies in their portability. Unlike physical copies, digital books can be stored and carried on a single device, such as a tablet or smartphone, saving valuable space and weight. This convenience makes it possible for readers to have their entire library at their fingertips, whether they are commuting, traveling, or simply enjoying a lazy afternoon at home. Additionally, digital files are easily searchable, enabling readers to locate specific information within seconds. With a few keystrokes, users can search for keywords, topics, or phrases, making research and finding relevant information a breeze. This efficiency saves time and effort, streamlining the learning process and allowing individuals to focus on extracting the information they need. Furthermore, the availability of free PDF books and manuals fosters a culture of continuous learning. By removing financial barriers, more people can access educational resources and pursue lifelong learning, contributing to personal growth and professional development. This democratization of knowledge promotes intellectual curiosity and empowers individuals to become lifelong learners, promoting progress and innovation in various fields. It is worth noting that while accessing free Mercedes Parts Manual PDF books and manuals is convenient and cost-effective, it is vital to respect copyright laws and intellectual property rights. Platforms offering free downloads often operate within legal boundaries, ensuring that the materials they provide are either in the public domain or authorized for distribution. By adhering to copyright laws, users can enjoy the benefits of free access to knowledge while supporting the authors and publishers who make these resources available. In conclusion, the availability of Mercedes Parts Manual free PDF books and manuals for download has revolutionized the way we access and consume knowledge. With just a few clicks, individuals can explore a vast collection of resources across different disciplines, all free of charge. This accessibility empowers individuals to become lifelong learners, contributing to personal growth, professional development, and the advancement of society as a whole. So why not unlock a world of knowledge today? Start exploring the vast sea of free PDF books and manuals waiting to be discovered right at your fingertips.

FAQs About Mercedes Parts Manual Books

1. Where can I buy Mercedes Parts Manual books? Bookstores: Physical bookstores like Barnes & Noble, Waterstones, and independent local stores. Online Retailers: Amazon, Book Depository, and various online bookstores offer a wide range of books in physical and digital formats.
2. What are the different book formats available? Hardcover: Sturdy and durable, usually more expensive. Paperback: Cheaper, lighter, and more portable than hardcovers. E-books: Digital books available for e-readers like Kindle or software like Apple Books, Kindle, and Google Play Books.

3. How do I choose a Mercedes Parts Manual book to read? Genres: Consider the genre you enjoy (fiction, non-fiction, mystery, sci-fi, etc.). Recommendations: Ask friends, join book clubs, or explore online reviews and recommendations. Author: If you like a particular author, you might enjoy more of their work.
4. How do I take care of Mercedes Parts Manual books? Storage: Keep them away from direct sunlight and in a dry environment. Handling: Avoid folding pages, use bookmarks, and handle them with clean hands. Cleaning: Gently dust the covers and pages occasionally.
5. Can I borrow books without buying them? Public Libraries: Local libraries offer a wide range of books for borrowing. Book Swaps: Community book exchanges or online platforms where people exchange books.
6. How can I track my reading progress or manage my book collection? Book Tracking Apps: Goodreads, LibraryThing, and Book Catalogue are popular apps for tracking your reading progress and managing book collections. Spreadsheets: You can create your own spreadsheet to track books read, ratings, and other details.
7. What are Mercedes Parts Manual audiobooks, and where can I find them? Audiobooks: Audio recordings of books, perfect for listening while commuting or multitasking. Platforms: Audible, LibriVox, and Google Play Books offer a wide selection of audiobooks.
8. How do I support authors or the book industry? Buy Books: Purchase books from authors or independent bookstores. Reviews: Leave reviews on platforms like Goodreads or Amazon. Promotion: Share your favorite books on social media or recommend them to friends.
9. Are there book clubs or reading communities I can join? Local Clubs: Check for local book clubs in libraries or community centers. Online Communities: Platforms like Goodreads have virtual book clubs and discussion groups.
10. Can I read Mercedes Parts Manual books for free? Public Domain Books: Many classic books are available for free as they're in the public domain. Free E-books: Some websites offer free e-books legally, like Project Gutenberg or Open Library.

Find Mercedes Parts Manual :

jack parsons aleister crowley

ivan most dangerous game

is gerald's game a true story

iso systems engineering

j. randy taraborrelli

it starts with us how many pages

~~japanese cute culture~~

~~james pharmacy bed and breakfast~~

~~is kensington publishing a vanity press~~

is the cosmetology exam hard

is pope francis illuminati

~~it ends with us book summary~~

~~jane goodall's family~~

jack the ripper and hh holmes

james walker diabetes

Mercedes Parts Manual :