

# SYSTEM WIRING DIAGRAMS

## Article Text

1994 Volkswagen Golf III

For Volkswagen Technical Site

Copyright © 1998 Mitchell Repair Information Company, LLC

Tuesday, December 07, 1999 11:19PM

### ARTICLE BEGINNING

1994 System Wiring Diagrams  
Volkswagen - Golf III

### AIR CONDITIONING

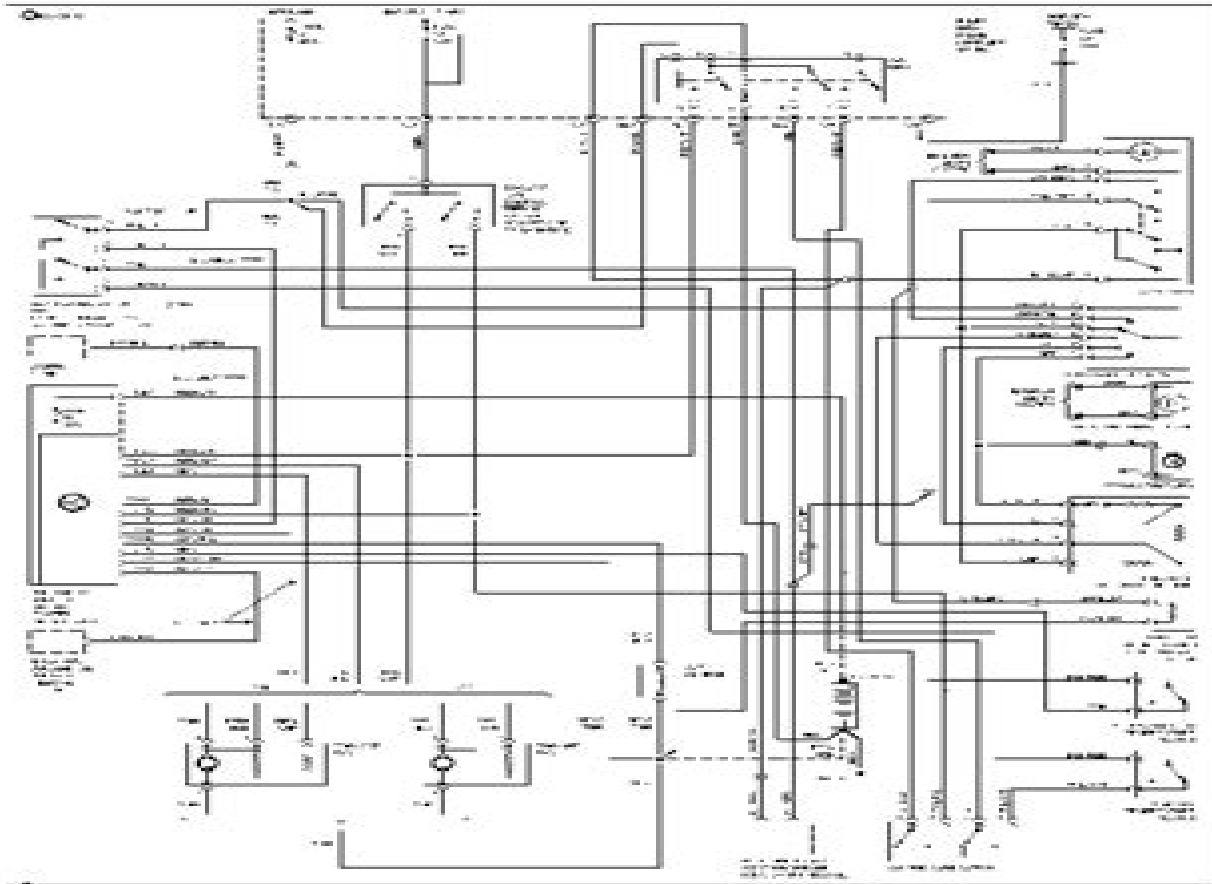

A/C Circuit

# **Golf 3 User Manual**

**DK, Nick Bradley**



# Golf 3 User Manual

The Complete Golf Manual Steve Newell,2019-11-05 Covering every possible aspect the game from tee shots iron play pitching and chipping to coping with bunkers and putting The Complete Golf Manual works is the ultimate self improvement guide to playing better golf With a series of exercises designed to develop your technique routines to help you think more decisively on the course and a section on the top 10 most common faults Steve Newell offers a fast track to a lower handicap for all from the novice to the experienced club golfer Golf Instruction Manual Steve Newell,Ernie Els,2007 Play better golf whatever your level From tee shots and iron play to pitching chipping and coping with bunkers find out how to play golf with expert tuition and easy to follow photographic sequences Improve your game with illustrated tests and drills that highlight key technical points Discover how to fix the 10 most common faults that can creep into your playing then check your progress with performance charts Learn about every aspect of golf from buying equipment to rules etiquette and golfing terms It s your fast track to a better game Complete Golf Manual Steve Newell,2010-05-03 Transform your golf game with this expert guide and lower your handicap too Learn to play like a pro and improve your golf game whether you are a novice or experienced club golfer You ll start by taking a test to discover your level of ability then follow progressive exercises designed to develop your golfing technique From tee shots to coping with bunkers learn to improve your golf swing immeasurably Give yourself the winning edge with over 160 practice drills then discover how to fix the top 10 most common faults that can creep into any golfers game Find expert tips on buying your golfing equipment learn the all important golf etiquette and refresh your memory on golf s most important rules and lingo It s the ultimate guide to playing better golf

2015 Volkswagen Golf Owner Manual Compatible with OEM Owners Manual, Factory Glovebox Book Helming,2015-02-06 *The Baby Owner's Manual* Louis Borgenicht M.D.,Joe Borgenicht,2012-11-06 At last A beginner s guide to newborn baby technology complete with step by step instructions FAQs and schematics from a board certified pediatrician and his son an older model Congratulations you ve just acquired one of life s biggest technological marvels a newborn baby New owners have so many questions How do I handle sleep malfunctions When should I bring the baby to a doctor for servicing What transportation accessories do I need New users will get plenty of useful advice on PREPARATION AND HOME INSTALLATION How to store your baby properly GENERAL CARE Effective techniques for handling holding and comforting the baby FEEDING An in depth guide to your baby s power supply from breastfeeding to solid food PROGRAMMING SLEEP MODE How to Configure baby s sleeping area and manage issues such as overstimulation GENERAL MAINTENANCE Keep that new baby smell fresh with tips on sanitation and care such as diaper installation and cleaning GROWTH AND DEVELOPMENT Perform user testing on baby s reflexes note and track milestones plus advanced motor and sensory skills SAFETY AND EMERGENCY MAINTENANCE Monitor baby s health tackle childproofing learn life saving

procedures plus get fixes for minor issues such as cradle cap and diaper rash Whatever your concerns celebrated pediatrician Dr Louis Borgenicht and his son Joe Borgenicht provide plenty of useful advice for anyone who wants to learn the basics of childcare [The Practice Manual](#) Adam Young,2015-01-25 [2012 Volkswagen Golf Owner Manual Compatible with OEM Owners Manual, Factory Glovebox Book](#) Helming,2012-03-29 *The Startup Owner's Manual* Steve Blank,Bob Dorf,2020-03-17 More than 100 000 entrepreneurs rely on this book for detailed step by step instructions on building successful scalable profitable startups The National Science Foundation pays hundreds of startup teams each year to follow the process outlined in the book and it s taught at Stanford Berkeley Columbia and more than 100 other leading universities worldwide Why *The Startup Owner s Manual* guides you step by step as you put the Customer Development process to work This method was created by renowned Silicon Valley startup expert Steve Blank co creator with Eric Ries of the Lean Startup movement and tested and refined by him for more than a decade This 608 page how to guide includes over 100 charts graphs and diagrams plus 77 valuable checklists that guide you as you drive your company toward profitability It will help you Avoid the 9 deadly sins that destroy startups chances for success Use the Customer Development method to bring your business idea to life Incorporate the Business Model Canvas as the organizing principle for startup hypotheses Identify your customers and determine how to get keep and grow customers profitably Compute how you ll drive your startup to repeatable scalable profits *The Startup Owner s Manual* was originally published by K S Ranch Publishing Inc and is now available from Wiley The cover design and content are the same as the prior release and should not be considered a new or updated product **Volkswagen Golf 1993 Owner's Manual** Volkswagen Of America,1992-10-01 [VW Golf and Jetta Restoration Manual](#) Lindsay Porter,2000-10-14 Volkswagen s Golf Rabbit and Jetta models are popular and enduring cars Well known for their robustness and need for minimum maintenance these vehicles often suffer from neglect by their owners Restoration expert Lindsay Porter fills you in on VW history and development tells you what to look for and what to avoid when buying an older model and how to bring it back to first class condition Fully illustrated sequences guide you step by step through a mechanical overhaul and show you how to restore bodywork interior and electrics Includes soft top mechanism replacement *The Wedge Book* Brandon Stooksbury,Tim Oliver,2015-09-07 Short game shots in your golf game don t have to be complicated unless you re getting all kinds of conflicting information about technique and strategy In *The Wedge Book* Brandon Stooksbury cuts through the confusion and provides you a clear straightforward plan to build your short game from the smallest bump and run to a 50 yard pitch shot By using the same baseline technique and adding specific elements for certain shots you ll be able to take away the mystery and indecision that can ruin a golf hole so easily Stooksbury s advice has been proven in the highest levels of competitive golf And now with *The Wedge Book* and a month or so of practice you can take it to your course [Industry and Product Classification Manual](#) United States. SIC Coding Task Group,1977 **Volkswagen GTI Golf-Jetta Service Manual, 1985-1992** Robert Bentley, inc,1992 New information

covers the 2.0 liter 16V engine ABS troubleshooting service CIS E Motronic fuel injection Digifant I fuel injection with On Board Diagnosis ECO Diesel full manual transaxle rebuilding procedures A special Fundamentals section has been added to the beginning of the manual to help the owner understand the basics of automotive systems repair procedures The most comprehensive Golf manual available **Industry and Product Classification Manual**, 1987 [Volkswagen Golf 1995 Owner's Manual](#) Volkswagen Of America, 1994-10-01 [Volkswagen Golf 1987 Owner's Manual](#) Volkswagen Of America, 1986-10-01 **Volkswagen Golf/Gti A3 1999 Owner's Manual** Volkswagen Of America, 1998-10-01

[Volkswagen Golf 1994 Owner's Manual](#) Volkswagen Of America, 1993-10-01 *The Golf Book* DK, Nick Bradley, 2021-09-16 Discover the history of one of the world's most popular sports and learn how to master the perfect swing along the way Find out all there is to know about golf from its ancient origins to its most celebrated competitions Learn about the turning points and winning strokes of the most famous championships ever played from the Open to the Curtis Cup Bringing you face to face with the stars such as Tiger Woods The Golden Bear and The Shark entries analyse their trademark strokes and detail their finest performances Showing you exactly what it takes to achieve an effective and consistent golf swing this ebook also walks you through the fairways of all the pre eminent courses while working systematically through every type of shot from tee shots iron play pitching and chipping to coping with bunkers and putting Learn the sport's key rules and golfing terms and discover everything you need to know about how to buy the right equipment from drivers to carts along with guidance on custom fitting and the all important golf etiquette Brimming with detail and superbly illustrated with over 1 500 photographs illustrations maps and diagrams The Golf Book is the definitive guide to the famous game for players and fans alike **Golf bible** Steve Newell, Dae Hyuk Choi, 2005

**warhammer game wikipedia** - Dec 27 2021

web feb 11 2021 4 21pm feb 11 2021 5 46pm 2 change notes view created by aranfan online see the collection may be hidden subscribe to download warhammer

**printable spellcards r warhammerfantasy reddit** - Jul 14 2023

web jun 19 2020 printable spellcards hello fellow fantasy fans i know how hard and a bit pricey it is to find spell cards this is why i have started making my own and share with

**warhammer quest spell cards pdf magician fantasy** - Jan 28 2022

web february 2022 warhammer is set in a fictional universe notable for its dark and gritty background world which features influences from michael moorcock's elric stories and

**frostgrave spell cards frostgrave element games** - Oct 25 2021

web battle magic spells these spells are the ones used by non specialist wizards and are also available for use by alchemists

and some clerics they cover a wide range of defensive  
[spells warhammer fantasy 8th edition](#) - Apr 11 2023

web the shaman that casts the spell has 3 attacks 3 strength and a 6 ward save as long as the spell remains in play spells of  
da big waaagh if a spell of da big waaagh

[wfrp 4e sullasara s spells pdf new magic spells reddit](#) - Feb 26 2022

web warhammer quest spell cards read online for free all the spells from the roleplay book as printable cards

**steam workshop warhammer fantasy 8th edition spell cards** - Nov 25 2021

web frostgrave spell cards frostgrave fantasy miniatures games wargaming web store with low prices speedy delivery and  
excellent customer service specialising in

[warhammer fantasy online rules index project](#) - Sep 04 2022

web this spell can affect a single infantry unit within 24 and line of sight of the caster if successfully cast the spell turns 4d6  
of the targeted unit s models into clanrats if the

**printable cards the dreaded thirteenth spell warhammer** - Aug 03 2022

web official magic card gaming aids for whfb 6e these warhammer magic cards have been created to use as gaming aids so  
that you don t need to keep notes or keep referring to

**warhammer fantasy spell cards for sale ebay** - Oct 05 2022

web welcome to the warhammer fantasy online rules index project the goal of this project is to make it easy to quickly look  
up rules and references for almost any edition of

[printable cards skaven spells of ruin warhammer fantasy](#) - Dec 07 2022

web in addition if a direct damage or magic missile spell from the lore of fire is cast at a unit that has already been hit by a  
direct damage or magic missile spell from the lore of fire

**list of spells warhammer the old world lexicanum** - Apr 30 2022

web 1 cascading fire cloak 5 augment target unit all target units currently in range is 1 to be hit with shooting each enemy  
unit in base contact with the caster or his unit at the end

**battle magic cards cataclysm and cantrip spell cards** - Feb 09 2023

web the casting player can decide to end the spell or pass it to another target within 12 of a unit affected by the spell during  
his magic phase the unit selected suffers as above units

[warhammer battle magic warhammer the old world](#) - Jun 01 2022

web dec 15 2019 list sources 1 warhammer fantasy roleplay 2th edition arcane lores pg 149 151 2 warhammer armies the  
empire 4th edition ice magic spells pg 75

[printable cards spells of da big waaagh warhammer fantasy](#) - Mar 10 2023

web description in warhammer storm of magic battles there are plenty more spells for you to cast with your wizards so many in fact that we've created a set of cards to help you

**whfb 6e magic cards tabletop campaign repository** - Jul 02 2022

web feb 25 2023 135 spell cards including 10 for light magic 10 for gold magic 10 for jade magic 10 for celestial magic 10 for grey magic 10 for amethyst magic 10 for bright

[printable cards skaven spells of plague warhammer fantasy](#) - Jan 08 2023

web if the number of hits rolled is 1 then the caster suffers a strength 5 hit instead of the target skaven spells of ruin 3 howling warpgale casts on 7 this spell lasts until the start

[printable cards the lore of fire warhammer fantasy 8th edition](#) - Nov 06 2022

web find great deals on ebay for warhammer fantasy spell cards shop with confidence

**warhammer fifth edition magic board game boardgamegeek** - May 12 2023

web mar 13 2022 each wizard knows a number of spells equal to his level chosen randomly at the start of each battle in the magic phase your wizards unleash their magical power

**printable cards warhammer fantasy 8th edition** - Aug 15 2023

web spell cards the dreaded thirteenth spell the lore of beasts the lore of dark magic dark elves the lore of dark magic wood elves the lore of death the lore of fire

[warhammer 8th ed magic playsheet pdf dice armour scribd](#) - Mar 30 2022

web 25 comments add a comment deleted 2 yr ago pdf only blurb sullasara's spells of unrivalled utility when teclis decided to instruct the humans of the empire in

[spells warhammer fantasy roleplay first edition wiki](#) - Sep 23 2021

**battle magic warhammer wiki fandom** - Jun 13 2023

web contents warhammer magic rulebook magic item cards 81 magic weapon items 42 enchanted magic items 18 magic armour items 36 wizard arcana items 6 magic ward

[buy big boys use the potty in bulk 9780756614515](#) - Jan 13 2022

web overview take the worry out of potty training with this fun and informative guide that encourages your child to use the potty like a big boy now your child can be potty perfect with this step by step guide to using the potty with pride

**big boys use the potty by dk publishing goodreads** - Jan 25 2023

web read 13 reviews from the world's largest community for readers excellent book

big boys use the potty a book by dk bookshop - Jun 17 2022

web take the worry out of potty training with this fun and informative guide that encourages your child to use the potty like a big boy now your child can be potty perfect with this step by step guide to using the potty with pride with lots of helpful friendly advice and special reward stickers to encourage success soon your toddler will be able to say bye bye

**big boys use the potty penguin random house** - Apr 27 2023

web about big boys use the potty take the worry out of potty training with this fun and informative guide that encourages your child to use the potty like a big boy now your child can be potty perfect with this step by step guide to using the potty with pride

**big boys use the potty by dk publishing open library** - Feb 23 2023

web aug 18 2008 big boys use the potty by dk publishing august 18 2008 dk preschool edition paperback in english

**big boys use the potty dk google books** - Aug 20 2022

web aug 15 2005 big boys use the potty dk national geographic books aug 15 2005 juvenile nonfiction 12 pages take the worry out of potty training with this fun and informative guide that encourages

**big boys use the potty dk us** - Jul 31 2023

web aug 15 2005 take the worry out of potty training with this fun and informative guide that encourages your child to use the potty like a big boy now your child can be potty perfect with this step by step guide to using the potty with pride with lots of helpful friendly advice and special reward stickers

**big boys use the potty by dk alibris** - Feb 11 2022

web buy big boys use the potty by dk online at alibris we have new and used copies available in 1 editions starting at 0 99 shop now

*big boys use the potty indigo books music inc* - Sep 20 2022

web take the worry out of potty training with this fun and informative guide that encourages your child to use the potty like a big boy now your child can be potty perfect with this step by step guide to using the potty with pride with lots of helpful friendly advice and special reward stickers to encourage success soon your toddler will be able to say bye bye

*big boys use the potty by dk amazon ae* - May 29 2023

web about big boys use the potty take the worry out of potty training with this fun and informative guide that encourages your child to use the potty like a big boy now your child can be potty perfect with this step by step guide to using the potty with pride

*big boys use the potty by dk august 15 2005 board book* - Oct 22 2022

web big boys use the potty by dk august 15 2005 board book on amazon com free shipping on qualifying offers big boys use



the potty by dk august 15 2005 board book

**big boys use the potty by dk board book barnes noble** - Nov 22 2022

web aug 15 2005 overview take the worry out of potty training with this fun and informative guide that encourages your child to use the potty like a big boy now your child can be potty perfect with this step by step guide to using the potty with pride

big boys use the potty dk amazon co uk books - Dec 24 2022

web aug 15 2005 big boys use the potty board book sticker book 15 aug 2005 by dk author 4 3 527 ratings see all formats and editions take the worry out of potty training with this fun and informative guide that encourages your child to use the potty like a

big boys use the potty by dk board book target - Apr 15 2022

web sep 1 2005 big boys use the potty by dk board book 7 99when purchased online in stock add to cart about this item specifications dimensions overall 7 76 inches h x 7 78 inches w x 36 inches d weight 5 pounds suggested age 2 5 years sub genre health daily living genre juvenile nonfiction number of pages 12

big boys use the potty dk publishing amazon com be books - Jul 19 2022

web big boys use the potty dk publishing amazon com be books books children s books growing up facts of life buy new 195 00 3 delivery 11 18 october

*big boys use the potty pinnington andrea free download* - Sep 01 2023

web mar 30 2022 big boys use the potty pinnington andrea free download borrow and streaming internet archive by pinnington andrea publication date 2005 topics toilet training juvenile fiction child rearing toilet training fiction stories in rhyme publisher new york n y dk pub collection

**big boys use the potty by dk 2005 children s board books** - Mar 15 2022

web big boys use the potty by dk 2005 children s board books 3 product ratings expand ratings current slide current slide of total slides top picked items brand new

**big boys use the potty dk 9780756614515 abebooks** - May 17 2022

web condition new board books take the worry out of potty training with this fun and informative guide that encourages your child to use the potty like a big boy now your child can be potty perfect with this step by step guide to using the potty with pride

**big boys use the potty by dk publishing open library** - Mar 27 2023

web aug 15 2005 big boys use the potty by dk publishing august 15 2005 dk preschool edition board book in english brdbk edition

**big boys use the potty dk 9780756614515 amazon com books** - Jun 29 2023

web aug 15 2005 board book 7 99 50 used from 1 21 16 new from 6 47 take the worry out of potty training with this fun and informative guide that encourages your child to use the potty like a big boy now your child can be potty perfect with this step by step guide to using the potty with pride

**paul tipler gene mosca reverté help environment harvard edu** - Jul 02 2022

web if you object to download and install the paul tipler gene mosca reverté it is entirely easy then before currently we extend the partner to buy and make bargains to download and install paul tipler gene mosca reverté for that reason simple loose leaf version for physics for scientists and engineers extended version 2020 update paul a

**ÇomÜ tıp fakültesi** - Apr 30 2022

web dilek ve Önerileriniz İçin Rİmer rektörlük İletişim merkezi dilek talep Öneri ÖĞrencİ akademik takvim Öğrenci bilgi sistemi

**tıpta genetiĞİN rolü İrenbe tüp bebek merkezi** - Feb 26 2022

web may 1 2019 kısmen veya tamamen genetik faktörlerin rol oynadığı hastalıklar üçe ayrılabilir 1 tek gen hastalıkları 2 kromozom hastalıkları 3 multifaktöriyel hastalıklar tek gen hastalıkları bir tek genin mutasyona uğraması sonucu tek bir gen tarafından taşınan genetik bilgide önemli bir hata olmuştur

*kanatlı yapısıyla pegasus a benzeyen türk mitolojisindeki* - Mar 30 2022

web feb 10 2021 türk mitolojisinde evren gök yer ve yer altı olmak üzere üç kısımdan oluşur ve her kısımda farklı varlıklar bulunur sizlerin de tahmin ettiği gibi yer altında karanlık varlıklar yeryüzünde bizler hayvanlar ve bitkiler gökte ise kutsal varlıklar yer alıyor tulpın ise uçması ve kanatları olması sebebiyle

*physics for scientists and engineers 6th edition by paul a tipler* - Sep 04 2022

web physics for scientists and engineers 6th edition by paul a tipler gene mosca link download smartebook us physics for scientists and engineers 6th edition

física para la ciencia y la tecnología i 6 ed reverté - Apr 11 2023

web jan 1 2010 paul allen tipler gene mosca física para la ciencia y la tecnología dada su impecable claridad y precisión se ha constituido en una referencia obligada de los cursos universitarios de física de casi todo el mundo

**física para la ciencia y la tecnología vol 2 electricidad y** - Oct 05 2022

web física para la ciencia y la tecnología vol 2 electricidad y magnetismo luz 6ª edición tipler paul allen mosca gene amazon es libros

*física para la ciencia y la tecnología 6ª edición física moderna* - Nov 06 2022

web la sexta edición de la reconocida obra de tipler mosca ha sido objeto de una revisión exhaustiva y escrupulosa de todos

los contenidos del libro con el objetivo de lograr un manual aún más didáctico y de incorporar en él los nuevos conceptos de la física en que se sustentan los recientes avances de la tecnología

**reversi nasıl oynanır zeka oyunu reversi toplam kaç hürriyet** - Jan 28 2022

web sep 22 2021 reversi iki kişinin oynadığı güzel bir zekâ oyunudur reversi nasıl oynanır reversi bir masa oyunudur ve iki kişi tarafından oynanmaktadır

**física para la ciencia y la tecnología paul a tipler gene mosca** - Feb 09 2023

web física para la ciencia y la tecnología paul a tipler gene mosca por tipler paul allen colaborador es mosca gene tipo de material texto detalles de publicación barcelona reverté 2010 edición 6ª ed descripción v il col 28 cm isbn 9788429144284 o c 9788429144291 v 1 9788429144307 v 2 9788429144260 v 3

*física para la ciencia y la tecnología i paul allen tipler gene* - Jun 13 2023

web paul allen tipler gene mosca reverté 2004 science 660 pages durante casi 30 años la física para la ciencia y la tecnología de paul a tipler ha sido una referencia obligada de

**física para la ciencia y la tecnología vol 2 electricidad y** - Jul 14 2023

web apr 7 2021 paul allen tipler gene mosca reverté apr 7 2021 science 513 pages física para la ciencia y la tecnología dada su impecable claridad y precisión se ha constituido en una referencia obligada de los cursos

**physik für wissenschaftler und ingenieure springerlink** - Dec 07 2022

web paul a tipler gene mosca pages 529 543 die kinetische gastheorie paul a tipler gene mosca pages 545 565 wärme und der erste hauptsatz der thermodynamik paul a tipler gene mosca pages 567 598 previous page page 1 navigate to page number of 3 next page back to top about this book

*paul tipler gene mosca reverté com copy* - Aug 03 2022

web paul tipler gene mosca reverté com physics for scientists and engineers study guide apr 08 2020 the study guide provides students with key physical quantities and equations misconceptions to avoid questions and practice problems to gain further understanding of physics concepts and quizzes to test student knowledge of chapters

**düzen laboratuvarlar grubu diyabette genetik etkenler** - Jun 01 2022

web tip 1 diyabette olduğu gibi tip 2 diyabette de çevresel faktörlerin yanında genetik faktörlerin de rol oynadığı bilinmektedir son zamanlarda yapılan genetik çalışmalar ile birçok anahtar gen başarıyla tanımlanmıştır hastalık gelişiminde capn10 pparg ve tcf7l2 kcnj11 ve hnf4a gibi genlerin majör enpp1 gibi bazı

**tipler p mosca g 2010 física para la ciencia y la** - Aug 15 2023

web nov 9 2020 vol 1 c 6ta ed edit reverté paul tipler gene mosca free download borrow and streaming internet archive tipler p mosca g 2010 física para la ciencia y la tecnología termodinámica vol 1 c 6ta ed edit reverté física de tipler mosca

volumen 1c termodinámica de la sexta edición

física para la ciencia y la tecnología electricidad y magnetismo 2a - Jan 08 2023

web paul allen tipler gene mosca reverté 2005 science 317 pages durante casi 30 años la física para la ciencia y la tecnología de paul a tipler ha sido una referencia obligada de

**física para la ciencia y la tecnología 1a mecánica paul a tipler** - Mar 10 2023

web paul a tipler gene mosca editorial reverté s a 2010 science 490 pages física para la ciencia y la tecnología dada su impecable claridad y precisión se ha constituido en una

**física para la ciencia y la tecnología vol 1 mecánica** - Dec 27 2021

web apr 7 2021 paul allen tipler gene mosca reverté apr 7 2021 science 702 pages física para la ciencia y la tecnología dada su impecable claridad y precisión se ha constituido en una

**physics for scientists and engineers paul a tipler gene mosca** - May 12 2023

web jul 10 2003 paul a tipler gene mosca macmillan jul 10 2003 science 1116 pages for nearly 30 years paul tipler s physics for scientists and engineers has set the standard in the

## Unveiling the Magic of Words: A Review of "**Golf 3 User Manual**"

In a global defined by information and interconnectivity, the enchanting power of words has acquired unparalleled significance. Their power to kindle emotions, provoke contemplation, and ignite transformative change is really awe-inspiring. Enter the realm of "**Golf 3 User Manual**," a mesmerizing literary masterpiece penned by way of a distinguished author, guiding readers on a profound journey to unravel the secrets and potential hidden within every word. In this critique, we shall delve in to the book is central themes, examine its distinctive writing style, and assess its profound effect on the souls of its readers.

[https://offsite.creighton.edu/files/virtual-library/Documents/health\\_science\\_reasoning\\_test.pdf](https://offsite.creighton.edu/files/virtual-library/Documents/health_science_reasoning_test.pdf)

[https://offsite.creighton.edu/files/virtual-library/Documents/hiding\\_place\\_corrie\\_ten\\_boom.pdf](https://offsite.creighton.edu/files/virtual-library/Documents/hiding_place_corrie_ten_boom.pdf)

[https://offsite.creighton.edu/files/virtual-library/Documents/henrys\\_freedom\\_box\\_pdf.pdf](https://offsite.creighton.edu/files/virtual-library/Documents/henrys_freedom_box_pdf.pdf)

### **Table of Contents Golf 3 User Manual**

1. Understanding the eBook Golf 3 User Manual
  - The Rise of Digital Reading Golf 3 User Manual
  - Advantages of eBooks Over Traditional Books
2. Identifying Golf 3 User Manual
  - Exploring Different Genres
  - Considering Fiction vs. Non-Fiction
  - Determining Your Reading Goals
3. Choosing the Right eBook Platform
  - Popular eBook Platforms

- Features to Look for in an Golf 3 User Manual
- User-Friendly Interface
- 4. Exploring eBook Recommendations from Golf 3 User Manual
  - Personalized Recommendations
  - Golf 3 User Manual User Reviews and Ratings
  - Golf 3 User Manual and Bestseller Lists
- 5. Accessing Golf 3 User Manual Free and Paid eBooks
  - Golf 3 User Manual Public Domain eBooks
  - Golf 3 User Manual eBook Subscription Services
  - Golf 3 User Manual Budget-Friendly Options
- 6. Navigating Golf 3 User Manual eBook Formats
  - ePub, PDF, MOBI, and More
  - Golf 3 User Manual Compatibility with Devices
  - Golf 3 User Manual Enhanced eBook Features
- 7. Enhancing Your Reading Experience
  - Adjustable Fonts and Text Sizes of Golf 3 User Manual
  - Highlighting and Note-Taking Golf 3 User Manual
  - Interactive Elements Golf 3 User Manual
- 8. Staying Engaged with Golf 3 User Manual
  - Joining Online Reading Communities
  - Participating in Virtual Book Clubs
  - Following Authors and Publishers Golf 3 User Manual
- 9. Balancing eBooks and Physical Books Golf 3 User Manual
  - Benefits of a Digital Library
  - Creating a Diverse Reading Collection Golf 3 User Manual
- 10. Overcoming Reading Challenges
  - Dealing with Digital Eye Strain
  - Minimizing Distractions
  - Managing Screen Time
- 11. Cultivating a Reading Routine Golf 3 User Manual

- 
- Setting Reading Goals Golf 3 User Manual
  - Carving Out Dedicated Reading Time
12. Sourcing Reliable Information of Golf 3 User Manual
    - Fact-Checking eBook Content of Golf 3 User Manual
    - Distinguishing Credible Sources
  13. Promoting Lifelong Learning
    - Utilizing eBooks for Skill Development
    - Exploring Educational eBooks
  14. Embracing eBook Trends
    - Integration of Multimedia Elements
    - Interactive and Gamified eBooks

### **Golf 3 User Manual Introduction**

In today's digital age, the availability of Golf 3 User Manual books and manuals for download has revolutionized the way we access information. Gone are the days of physically flipping through pages and carrying heavy textbooks or manuals. With just a few clicks, we can now access a wealth of knowledge from the comfort of our own homes or on the go. This article will explore the advantages of Golf 3 User Manual books and manuals for download, along with some popular platforms that offer these resources. One of the significant advantages of Golf 3 User Manual books and manuals for download is the cost-saving aspect. Traditional books and manuals can be costly, especially if you need to purchase several of them for educational or professional purposes. By accessing Golf 3 User Manual versions, you eliminate the need to spend money on physical copies. This not only saves you money but also reduces the environmental impact associated with book production and transportation. Furthermore, Golf 3 User Manual books and manuals for download are incredibly convenient. With just a computer or smartphone and an internet connection, you can access a vast library of resources on any subject imaginable. Whether you're a student looking for textbooks, a professional seeking industry-specific manuals, or someone interested in self-improvement, these digital resources provide an efficient and accessible means of acquiring knowledge. Moreover, PDF books and manuals offer a range of benefits compared to other digital formats. PDF files are designed to retain their formatting regardless of the device used to open them. This ensures that the content appears exactly as intended by the author, with no loss of formatting or missing graphics. Additionally, PDF files can be easily annotated, bookmarked, and searched for specific terms, making them highly practical for studying or referencing. When it comes to accessing Golf 3 User Manual books and manuals, several platforms offer an extensive collection of resources. One such platform is Project

Gutenberg, a nonprofit organization that provides over 60,000 free eBooks. These books are primarily in the public domain, meaning they can be freely distributed and downloaded. Project Gutenberg offers a wide range of classic literature, making it an excellent resource for literature enthusiasts. Another popular platform for Golf 3 User Manual books and manuals is Open Library. Open Library is an initiative of the Internet Archive, a non-profit organization dedicated to digitizing cultural artifacts and making them accessible to the public. Open Library hosts millions of books, including both public domain works and contemporary titles. It also allows users to borrow digital copies of certain books for a limited period, similar to a library lending system. Additionally, many universities and educational institutions have their own digital libraries that provide free access to PDF books and manuals. These libraries often offer academic texts, research papers, and technical manuals, making them invaluable resources for students and researchers. Some notable examples include MIT OpenCourseWare, which offers free access to course materials from the Massachusetts Institute of Technology, and the Digital Public Library of America, which provides a vast collection of digitized books and historical documents. In conclusion, Golf 3 User Manual books and manuals for download have transformed the way we access information. They provide a cost-effective and convenient means of acquiring knowledge, offering the ability to access a vast library of resources at our fingertips. With platforms like Project Gutenberg, Open Library, and various digital libraries offered by educational institutions, we have access to an ever-expanding collection of books and manuals. Whether for educational, professional, or personal purposes, these digital resources serve as valuable tools for continuous learning and self-improvement. So why not take advantage of the vast world of Golf 3 User Manual books and manuals for download and embark on your journey of knowledge?

### **FAQs About Golf 3 User Manual Books**

How do I know which eBook platform is the best for me? Finding the best eBook platform depends on your reading preferences and device compatibility. Research different platforms, read user reviews, and explore their features before making a choice. Are free eBooks of good quality? Yes, many reputable platforms offer high-quality free eBooks, including classics and public domain works. However, make sure to verify the source to ensure the eBook credibility. Can I read eBooks without an eReader? Absolutely! Most eBook platforms offer web-based readers or mobile apps that allow you to read eBooks on your computer, tablet, or smartphone. How do I avoid digital eye strain while reading eBooks? To prevent digital eye strain, take regular breaks, adjust the font size and background color, and ensure proper lighting while reading eBooks. What the advantage of interactive eBooks? Interactive eBooks incorporate multimedia elements, quizzes, and activities, enhancing the reader engagement and providing a more immersive learning experience. Golf 3 User Manual is one of the best book in our library for free trial. We provide copy of Golf 3 User Manual in digital format, so the resources that you find



are reliable. There are also many Ebooks of related with Golf 3 User Manual. Where to download Golf 3 User Manual online for free? Are you looking for Golf 3 User Manual PDF? This is definitely going to save you time and cash in something you should think about.

**Find Golf 3 User Manual :**

*health science reasoning test*

~~hiding place corrie ten boom~~

*henry's freedom box pdf*

[hatchet full movie](#)

**head and neck anatomy quiz**

*hiset math practice test with answers*

[holt geometry answers](#)

[hess's law practice problems](#)

**helicopter training books**

*harry potter i love magic*

~~hippie community near me~~

[hexagons in chemistry](#)

~~help with calculus problems~~

*helen keller imaging*

~~hebrew english bible dictionary~~

**Golf 3 User Manual :**