

4.2 Oil Change

4.2.1 Draining Used Oil

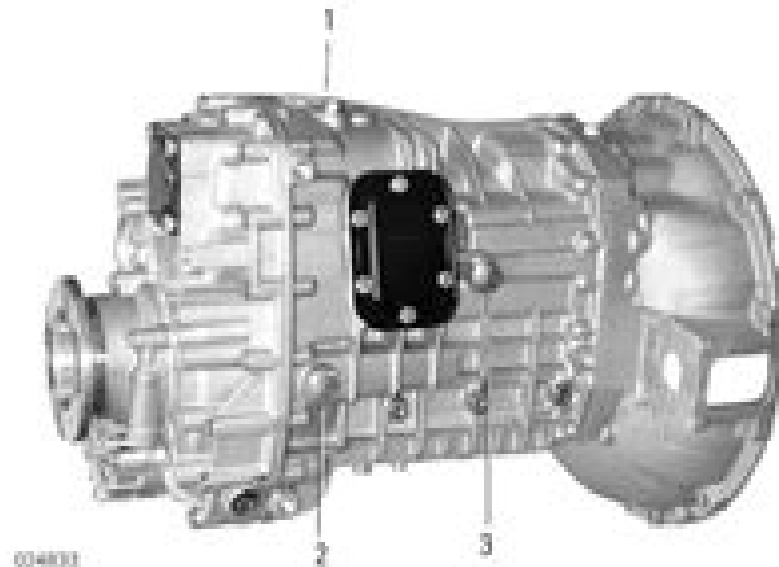

Fig. 11
Position of oil plugs (viewed from below) shown on model series 9 S 1110

- 1 Oil filler bore (50 Nm)
- 2 Oil drain plug (50 Nm)
- 3 Oil drain plug with magnetic plug (120 Nm)

CAUTION

Oil must not be allowed to enter the soil, ground water, or sewage system. Collect overflowing oil in a suitable container and dispose of in accordance with environmental guidelines.

NOTE

Basics: Change the oil after a long journey while the transmission oil is still thin and at operating temperature.



DANGER

Touching the hot transmission and transmission oil may result in burns!

To drain off the oil, unscrew and remove both drain plugs from the underside of the transmission (Fig. 11, Pos. 2 and 3), and also remove drain plugs from any items of auxiliary equipment.

Fit a new sealing ring to plug (2) before reinstalling.

On plug (3), before screwing the magnetic plug back into place, clean off any attached swarf and fit a new sealing ring.

Zf Transmission Repair Manual 9s1110

Jack Erjavec, Michael Ronan



Zf Transmission Repair Manual 9s1110

1993-94-95-96-1997 Ford Ranger 5R55E Transmission Repair Manual , This is the PDF service repair manual for the Ford Ranger 1993 1997 Transmission Transference 4x4 system The same manual auto shops and dealers reference to This is not your everyday off the shelf auto store manual This manual is guaranteed to be better than any auto store manual Detailed drawings Detail diagrams Detail step by step instructions Covers more than standard manuals Available as PDF no more damage manuals Chapters include Diagrams Transmission Transference Electrical 4R44E 5R55E Transmissions Automatic Manual 4wd 4x4 Gem Generic Module **How To Rebuild and Modify Your Manual Transmission** Robert Bowen, This resource explains how to rebuild and modify transmissions from both rear and front wheel drive cars It explains the principles behind the workings of all manual transmissions and helps readers understand what they need to do and know to rebuild their own transmissions Includes how to determine what parts to replace how and why to replace certain seals spacers springs forks and other parts and where to find and how to measure the specifications for each particular transmission *Max Ellery's Transmission Repair Manual Holden's 1963-1988* Max Ellery,1996-07-01 **Transmission Repair Book Ford 1960 to 2007** Max Ellery,2003-05-01 Automatic AOD BW 35 40 LE85 91 93 95 97 C4 C5 C6 C9 C10 FMX and M51 Manual 3 speed 4 speed and 5 speed single rail Top Loader T5 and M57 Step by step instructions for a pull down and rebuild Includes specifications torque settings problem diagnosis shift speeds plus more information This book is from an Australian publisher and covers both American and Australian applications **How to Rebuild and Modify High-Performance Manual Transmissions** Paul Cangialosi,2010 How to Rebuild and Modify High Performance Manual Transmissions breaks down the disassembly inspection modification upgrade and rebuilding process into detailed yet easy to follow steps consistent with our other Workbench series books The latest techniques and insider tips are revealed so an enthusiast can quickly perform a tear down identify worn parts select the best components and successfully assemble a high performance transmission Transmission expert and designer Paul Cangialosi shares his proven rebuilding methods insight and 27 years of knowledge in the transmission industry He guides you through the rebuilding process for most major high performance transmissions including BorgWarner T10 and super T10 GM Muncie Ford Toploader and Tremec T5 This new edition also contains a complete step by step rebuild of the Chrysler A833 transmission **Ford Automatic Transmission Overhaul** John Haynes,2001-10-13 Covers rear wheel drive models C3 C4 C5 C6 and AOD and front wheel drive models ATX FLC and AXOD Included are the fundamentals diagnosis techniques and modifications **Chilton's Automatic Transmission Repair Manual, 1984-1988** Chilton Automotive Books,1989-12-01 Chilton's Automatic Transmission/transaxle Diagnosis and Repair Jacques Gordon,Chilton Book Company,1999-02 Covers theory maintenance diagnosis and repair on all automatic transmissions and transaxles **Chevrolet Powerglide Automatic Transmission**

General Motors Corporation. Chevrolet Motor Division,1952 General Motors Automatic Transmission Overhaul John Haynes,2002-02-21 Covers rear wheel drive transmissions THM200 4R THM350 THM400 and THM700 R4 and front wheel drive transaxles THM125 125C THM3T40 THM440 T4 and THM4T60 *Chilton's Guide to Automatic Transmission Repair Manual, 1984-89* Chilton Automotive Books,1990-07-01 Explains how the automatic transmission works and provides instructions and technical information on how to repair it **Truck Unit Repair Manual** ,1978 Heavy Truck Repair Manual Motor Information Systems (Firm),2014 *Today's Technician: Manual Transmissions and Transaxles Classroom Manual and Shop Manual* Jack Erjavec,Michael Ronan,2018-12-17 Reflecting the latest ASE Education Foundation standards the fully updated Seventh Edition of TODAY S TECHNICIAN MANUAL TRANSMISSIONS TRANSAXLES covers must know topics including dual clutch systems limited slip differential designs and all wheel drive systems as well as essential safety concepts and major components of the transmission system and subsystems New material throughout the text gives readers an up to date understanding of the latest automotive technology and key advances in the fast changing automotive industry The authors have revised sections on electronic controls of transmissions transfer cases and differentials to feature the latest reprogramming techniques today s technicians need to know Covering both fundamental theory and practical job skills the text includes a Classroom Manual reviewing every topic for Manual Drive Train and Axles and a hands on Shop Manual with full color photo sequences and detailed job sheets including service and repair tasks based on the latest MLR AST and MAST task lists Important Notice Media content referenced within the product description or the product text may not be available in the ebook version **Heavy Truck Repair Manual** ,2010 Heavy Truck Repair Manual ,2020 **Today's Technician** Jack Erjavec,Michael Ronan,2019 *Car Shop Manual, 1984* Ford Motor Company,1984 **Today's Technician: Manual Transmissions & Transaxles Classroom Manual** Jack Erjavec,Michael Ronan,2018-12-17 Gear up for success in the classroom and shop in your future career with TODAY S TECHNICIAN MANUAL TRANSMISSIONS TRANSAXLES Seventh Edition This proven practical guide includes easy to understand information on a wide range of must know topics including transmission system and subsystem components shop safety basics dual clutch systems limited slip differential designs all wheel drive systems and six speed transmissions To help you master essential the Classroom Manual covers every topic for Manual Drive Train and Axles Important Notice Media content referenced within the product description or the product text may not be available in the ebook version Chrysler A-833 Transmissions Jamie Passon,2018-05-08 The photos in this edition are black and white Rebuild and modify your Chrysler A 833 transmission with confidence using expertise from author Jamie Passon of Passon Performance Jamie uses his decades of knowledge on the A 833 to create the ultimate book on rebuilding a Chrysler 4 speed Provides an historical overview of the long tenured A 833 and jumps into dissecting your transmission to assess what could be malfunctioning The bulk of the book concentrates on disassembling inspecting repairing and reassembling the A 833 With 400 photos the author shows exactly how to rebuild

your transmission and features how to sequences that walk you through each phase Making horsepower at Chrysler in the early 1960s was nothing new for the Pentastar brand The 413 RB engine had been producing more than 350 hp since the late 1950s Joining the lineup in 1963 the 426 Wedge doubled down on the fact that Chrysler was all in on going fast The one weakness holding them back from total domination on the streets and strips was with their dated and tired manual shifter the BorgWarner T 10 transmission That all changed with the advent of its replacement the New Process A833 Whether you own a Polara Road Runner Challenger or Ram truck you need to be certain that your transmission is in top notch working condition Now is the time to eliminate that annoying grind when you put your Mopar into reverse

Wong's Essentials of Pediatric Nursing ... Wong's Essentials of Pediatric Nursing (Essentials of Pediatric Nursing (Wong)). 9th Edition. ISBN-13: 978-0323083430, ISBN ... Wong's Essentials of Pediatric Nursing Wong's Essentials of Pediatric Nursing - Elsevier eBook on VitalSource, 9th Edition · Key Features. Developmental approach clearly identifies key issues at each ... Wong's Essentials of Pediatric Nursing Ninth Edition Amazon.com: Wong's Essentials of Pediatric Nursing Ninth Edition : Marilyn J. Hockenberry, David Wilson: Everything Else. Wong's Clinical Manual of Pediatric Nursing, 9th Edition Reflecting the latest in research and evidence-based practice, the book provides assessment tools and new information on pediatric pain assessment and ... Study Guide for Wong's Essentials of Pediatric Nursing ... May 6, 2021 — Updated to correspond to the bestselling textbook, the Study Guide for Wong's Essentials of Pediatric Nursing, 11th Edition features Next ... Wong's Essentials of Pediatric Nursing - E-Book ... edition of. Wong's Essentials of Pediatric Nursing. This tenth edition ... (9):771-783. Meek J, Huertas A. Cochrane review: non-nutritive sucking, kangaroo ... E BOOK: WONG'S ESSENTIALS OF PEDIATRIC NURSING E BOOK: WONG'S ESSENTIALS OF PEDIATRIC NURSING - PAGEBURST DIGITAL BOOK (RETAIL ACCESS CARD), 9TH EDITION · Author: · ISBN: · Publisher: · Volume: · Edition:. Wong's Essentials of Pediatric Nursing 9th edition The Digital and eTextbook ISBNs for Wong's Essentials of Pediatric Nursing are 9780323430845 and the print ISBNs are 9780323083430, 0323083439. Save up to 80% ... Wong's Essentials of Pediatric Nursing (9th Edition) by D ... Elsevier, 2013. This is an ex-library book and may have the usual library/used-book markings inside.This book has soft covers. Clean from markings. s Essentials of Pediatric Nursing by Marilyn J. Hockenberry ... Wong's Essentials of Pediatric Nursing by Marilyn J. Hockenberry Ninth Edition. I need to get a fuse panel layout and a wiring diagram for Mar 5, 2014 — I need to get a fuse panel layout and a wiring diagram for a 2000 Freightliner FL80. Having problems with the batteries going dead when it sets ... [DIAGRAM] 2000 Fl80 Fuse Box Diagram - YouTube Fuse Box Diagram for Freightliner FL80? Oct 22, 2022 — This diagram will be found through an image search. You might also be able find it in the users manual. 24-01117-000 | Freightliner FL80 Dash Panel for Sale SECONDARY COVER FOR FUSE BOX W/ DIAGRAM, SMALL CRACKS AROUND MOUNTING HOLES, LIGHTS, WIPER X2, PANEL LIGHTS, MIRROR HEAT. Type: CUP

HOLDER, FUSE COVER, IGNITION ... Freightliner Wiring Diagrams | PDF Freightliner wiring diagrams are divided by system function. This allows for many different options or accessory systems to be installed on the same model ... Wiring diagram for Freightliner rear compartment fuse box Sep 18, 2023 — I'm looking for a diagram that will show me a source for switched power in the rear fuse compartment by the chassis batteries in my 2018 ... 1994 Freightliner FL80 Fuse Diagram Just register your vehicle at this site for FREE. Once you are in, you can get Fusebox diagrams and complete chassis wiring layouts. If you do not have a ... need help with diagnosing tail light issues on a freightliner ... May 12, 2014 — ive went through all the fuses on the passenger side fuse panel either there is another fuse panel somewhere else, or a wire has be cut and ... Need wiring diagram for a 96 - 97 Freightliner Classic!!! Jul 5, 2012 — In your fuse box, you should have a 15 amp fuse marked panel or cluster. ... The service manual gives relay/circuit breaker layouts as well as, ... Spreadsheet Modeling & Decision Analysis (6th Edition) ... Access Spreadsheet Modeling & Decision Analysis 6th Edition solutions now. Our solutions are written by Chegg experts so you can be assured of the highest ... Spreadsheet Modeling & Decision Analysis 6th Edition Access Spreadsheet Modeling & Decision Analysis 6th Edition Chapter 6 solutions now. Our solutions are written by Chegg experts so you can be assured of the ... Solution Manual for Spreadsheet Modeling and Decision ... Solution Manual for Spreadsheet Modeling and Decision Analysis a Practical Introduction to Management Science 6th Edition by Ragsdale Full Download - Free ... Solution Manual for Spreadsheet Modeling and Decision ... View Test prep - Solution Manual for Spreadsheet Modeling and Decision Analysis A Practical Introduction to Business from TEST BANK 132 at DeVry University, ... Solutions manual for spreadsheet modeling and decision ... May 25, 2018 — Solutions Manual for Spreadsheet Modeling and Decision Analysis A Practical Introduction to Business Analytics 7th Edition by Cliff Ragsdale ... Spreadsheet Modeling & Decision Analysis SPREADSHEET MODELING AND DECISION ANALYSIS, Sixth Edition, provides instruction in the most commonly used management science techniques and shows how these ... Practical Management Science 6th Edition, WINSTON Textbook solutions for Practical Management Science 6th Edition WINSTON and others in this series. View step-by-step homework solutions for your homework. Spreadsheet Modeling & Decision Analysis [6 ed.] ... SPREADSHEET MODELING AND DECISION ANALYSIS, Sixth Edition, provides instruction in the most commonly used management sci... Complete Solution Manual Spreadsheet Modeling And ... Jun 20, 2023 — Complete Solution Manual Spreadsheet Modeling And Decision Analysis A Practical Introduction To Business Analytics 8th Edition Questions & ... Solution Manual for Spreadsheet Modeling and Decision ... Solution Manual for Spreadsheet Modeling and Decision Analysis 8th Edition by Ragsdale. Chapter 1. Introduction to Modeling & Problem Solving.

Immerse yourself in the artistry of words with Crafted by is expressive creation, Discover the Artistry of **Zf Transmission Repair Manual 9s1110** . This ebook, presented in a PDF format (*), is a masterpiece that goes beyond conventional storytelling. Indulge your senses in prose, poetry, and knowledge. Download now to let the beauty of literature and artistry envelop your mind in a unique and expressive way.

https://offsite.creighton.edu/files/virtual-library/Documents/honda_atv_repair.pdf

https://offsite.creighton.edu/files/virtual-library/Documents/how_did_the_cia_participate_in_the_cold_war.pdf

https://offsite.creighton.edu/files/virtual-library/Documents/how_much_is_a_diagnostic_test_at_toyota.pdf

Table of Contents Zf Transmission Repair Manual 9s1110

1. Understanding the eBook Zf Transmission Repair Manual 9s1110
 - The Rise of Digital Reading Zf Transmission Repair Manual 9s1110
 - Advantages of eBooks Over Traditional Books
2. Identifying Zf Transmission Repair Manual 9s1110
 - Exploring Different Genres
 - Considering Fiction vs. Non-Fiction
 - Determining Your Reading Goals
3. Choosing the Right eBook Platform
 - Popular eBook Platforms
 - Features to Look for in an Zf Transmission Repair Manual 9s1110
 - User-Friendly Interface
4. Exploring eBook Recommendations from Zf Transmission Repair Manual 9s1110
 - Personalized Recommendations

- Zf Transmission Repair Manual 9s1110 User Reviews and Ratings
- Zf Transmission Repair Manual 9s1110 and Bestseller Lists
- 5. Accessing Zf Transmission Repair Manual 9s1110 Free and Paid eBooks
 - Zf Transmission Repair Manual 9s1110 Public Domain eBooks
 - Zf Transmission Repair Manual 9s1110 eBook Subscription Services
 - Zf Transmission Repair Manual 9s1110 Budget-Friendly Options
- 6. Navigating Zf Transmission Repair Manual 9s1110 eBook Formats
 - ePub, PDF, MOBI, and More
 - Zf Transmission Repair Manual 9s1110 Compatibility with Devices
 - Zf Transmission Repair Manual 9s1110 Enhanced eBook Features
- 7. Enhancing Your Reading Experience
 - Adjustable Fonts and Text Sizes of Zf Transmission Repair Manual 9s1110
 - Highlighting and Note-Taking Zf Transmission Repair Manual 9s1110
 - Interactive Elements Zf Transmission Repair Manual 9s1110
- 8. Staying Engaged with Zf Transmission Repair Manual 9s1110
 - Joining Online Reading Communities
 - Participating in Virtual Book Clubs
 - Following Authors and Publishers Zf Transmission Repair Manual 9s1110
- 9. Balancing eBooks and Physical Books Zf Transmission Repair Manual 9s1110
 - Benefits of a Digital Library
 - Creating a Diverse Reading Collection Zf Transmission Repair Manual 9s1110
- 10. Overcoming Reading Challenges
 - Dealing with Digital Eye Strain
 - Minimizing Distractions
 - Managing Screen Time
- 11. Cultivating a Reading Routine Zf Transmission Repair Manual 9s1110
 - Setting Reading Goals Zf Transmission Repair Manual 9s1110
 - Carving Out Dedicated Reading Time
- 12. Sourcing Reliable Information of Zf Transmission Repair Manual 9s1110
 - Fact-Checking eBook Content of Zf Transmission Repair Manual 9s1110

- Distinguishing Credible Sources
- 13. Promoting Lifelong Learning
 - Utilizing eBooks for Skill Development
 - Exploring Educational eBooks
- 14. Embracing eBook Trends
 - Integration of Multimedia Elements
 - Interactive and Gamified eBooks

Zf Transmission Repair Manual 9s1110 Introduction

Zf Transmission Repair Manual 9s1110 Offers over 60,000 free eBooks, including many classics that are in the public domain. Open Library: Provides access to over 1 million free eBooks, including classic literature and contemporary works. Zf Transmission Repair Manual 9s1110 Offers a vast collection of books, some of which are available for free as PDF downloads, particularly older books in the public domain. Zf Transmission Repair Manual 9s1110 : This website hosts a vast collection of scientific articles, books, and textbooks. While it operates in a legal gray area due to copyright issues, its a popular resource for finding various publications. Internet Archive for Zf Transmission Repair Manual 9s1110 : Has an extensive collection of digital content, including books, articles, videos, and more. It has a massive library of free downloadable books. Free-eBooks Zf Transmission Repair Manual 9s1110 Offers a diverse range of free eBooks across various genres. Zf Transmission Repair Manual 9s1110 Focuses mainly on educational books, textbooks, and business books. It offers free PDF downloads for educational purposes. Zf Transmission Repair Manual 9s1110 Provides a large selection of free eBooks in different genres, which are available for download in various formats, including PDF. Finding specific Zf Transmission Repair Manual 9s1110, especially related to Zf Transmission Repair Manual 9s1110, might be challenging as theyre often artistic creations rather than practical blueprints. However, you can explore the following steps to search for or create your own Online Searches: Look for websites, forums, or blogs dedicated to Zf Transmission Repair Manual 9s1110, Sometimes enthusiasts share their designs or concepts in PDF format. Books and Magazines Some Zf Transmission Repair Manual 9s1110 books or magazines might include. Look for these in online stores or libraries. Remember that while Zf Transmission Repair Manual 9s1110, sharing copyrighted material without permission is not legal. Always ensure youre either creating your own or obtaining them from legitimate sources that allow sharing and downloading. Library Check if your local library offers eBook lending services. Many libraries have digital catalogs where you can borrow Zf Transmission Repair Manual 9s1110 eBooks for free, including popular titles. Online Retailers: Websites like Amazon, Google Books, or Apple Books often sell eBooks. Sometimes, authors or publishers offer promotions or free periods for certain books. Authors Website Occasionally, authors provide

excerpts or short stories for free on their websites. While this might not be the Zf Transmission Repair Manual 9s1110 full book, it can give you a taste of the authors writing style. Subscription Services Platforms like Kindle Unlimited or Scribd offer subscription-based access to a wide range of Zf Transmission Repair Manual 9s1110 eBooks, including some popular titles.

FAQs About Zf Transmission Repair Manual 9s1110 Books

1. Where can I buy Zf Transmission Repair Manual 9s1110 books? Bookstores: Physical bookstores like Barnes & Noble, Waterstones, and independent local stores. Online Retailers: Amazon, Book Depository, and various online bookstores offer a wide range of books in physical and digital formats.
2. What are the different book formats available? Hardcover: Sturdy and durable, usually more expensive. Paperback: Cheaper, lighter, and more portable than hardcovers. E-books: Digital books available for e-readers like Kindle or software like Apple Books, Kindle, and Google Play Books.
3. How do I choose a Zf Transmission Repair Manual 9s1110 book to read? Genres: Consider the genre you enjoy (fiction, non-fiction, mystery, sci-fi, etc.). Recommendations: Ask friends, join book clubs, or explore online reviews and recommendations. Author: If you like a particular author, you might enjoy more of their work.
4. How do I take care of Zf Transmission Repair Manual 9s1110 books? Storage: Keep them away from direct sunlight and in a dry environment. Handling: Avoid folding pages, use bookmarks, and handle them with clean hands. Cleaning: Gently dust the covers and pages occasionally.
5. Can I borrow books without buying them? Public Libraries: Local libraries offer a wide range of books for borrowing. Book Swaps: Community book exchanges or online platforms where people exchange books.
6. How can I track my reading progress or manage my book collection? Book Tracking Apps: Goodreads, LibraryThing, and Book Catalogue are popular apps for tracking your reading progress and managing book collections. Spreadsheets: You can create your own spreadsheet to track books read, ratings, and other details.
7. What are Zf Transmission Repair Manual 9s1110 audiobooks, and where can I find them? Audiobooks: Audio recordings of books, perfect for listening while commuting or multitasking. Platforms: Audible, LibriVox, and Google Play Books offer a wide selection of audiobooks.
8. How do I support authors or the book industry? Buy Books: Purchase books from authors or independent bookstores. Reviews: Leave reviews on platforms like Goodreads or Amazon. Promotion: Share your favorite books on social media or recommend them to friends.

9. Are there book clubs or reading communities I can join? Local Clubs: Check for local book clubs in libraries or community centers. Online Communities: Platforms like Goodreads have virtual book clubs and discussion groups.
10. Can I read Zf Transmission Repair Manual 9s1110 books for free? Public Domain Books: Many classic books are available for free as they're in the public domain. Free E-books: Some websites offer free e-books legally, like Project Gutenberg or Open Library.

Find Zf Transmission Repair Manual 9s1110 :

honda atv repair

how did the cia participate in the cold war

how much is a diagnostic test at toyota

hotels near cd and me

how to be a 3 man book

how does comparative anatomy support the theory of evolution

how do managers perform their job according to john kotter

hooked on phonics review

horse/human heart connection

how to become a notary in florida

how do you write a phone call in a screenplay

how long does it take to become a truck broker

how many questions are on the chemistry regents

how many dogs played marley

how long is the ap european history exam

Zf Transmission Repair Manual 9s1110 :